

3 EACH $\phi 7/16$ " HOLES
ON A $\phi 15.3$ BOLT CIRCLE

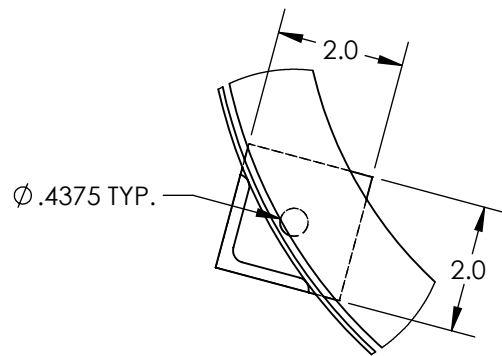

DETAIL A
SCALE 1 : 3

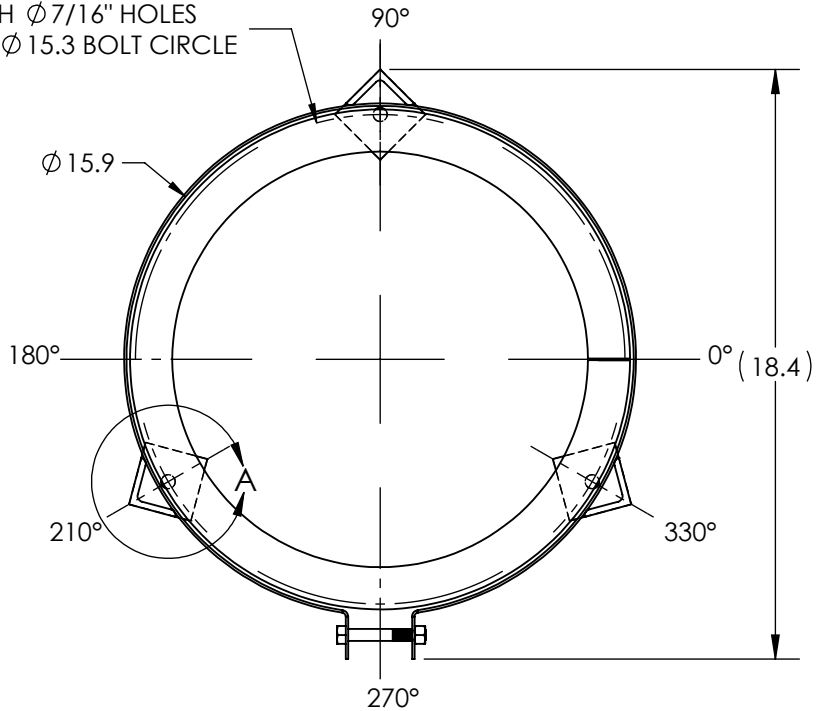
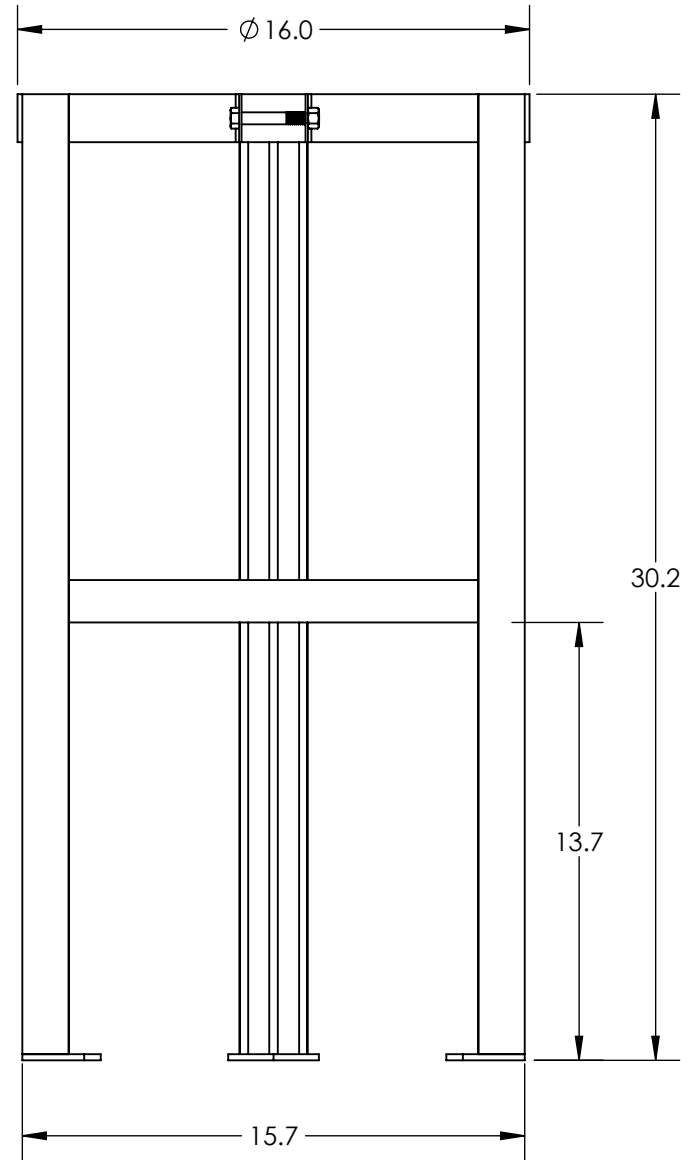

NOTES:

1. ALL WELDED CARBON STEEL CONSTRUCTION.
2. STAND TO BE PAINTED BLACK.
3. FOOT PAD HOLES SIZED TO ACCOMODATE 3/8" ANCHOR BOLTS.
4. STAND MUST BE SECURED TO A CONCRETE PAD USING PROPERLY SIZED ANCHORS PRIOR TO ANY LOADING.

***ALL EXTERNAL PIPING MUST BE INDEPENDENTLY SUPPORTED.**
***ONLY BASE FITTINGS TO BE LEFT INSTALLED AT TIME OF SHIPMENT PER SHI PROCEDURE.**
***Consult Snyder's Guidelines for Use and Installation prior to delivery.**
 Available on-line at <http://www.snyderindustriestanks.com/Technical>
ALL DIMENSIONS ARE IN INCHES, NOMINAL, & SUBJECT TO CHANGE WITHOUT NOTICE.
ALL DIMENSIONS ON ROTATIONAL MOLDED PARTS ARE SUBJECT TO A \pm 3% TOLERANCE.

DO NOT SCALE		TITLE: ASM STAND PAINTED STEEL 15CB		REVISION A
STATUS: Released		PART NO. 48900000		SHEET 1 OF 1
© TANK HOLDING, CORP, 2026		ENG. ID. D013640		
<small>ALL DIMENSIONS, DESIGNS, AND INFORMATION ON THIS PRINT MUST BE CONSIDERED PROPRIETARY TO TANK HOLDING, CORP. AND MAY NOT BE USED, COPIED, OR DISTRIBUTED WITHOUT WRITTEN PERMISSION OF AN OFFICER (OR HIS AGENT) OF THE FIRM.</small> www.tankholding.com				