

PART NUMBER	GASKET MATERIAL	BOLT LENGTH	DIM. "X"
34100118	EPDM	SHORT	.2813"
34701108	VITON	SHORT	.2813"
34100570	EPDM	LONG	1.0313"
34702949	VITON	LONG	1.0313"

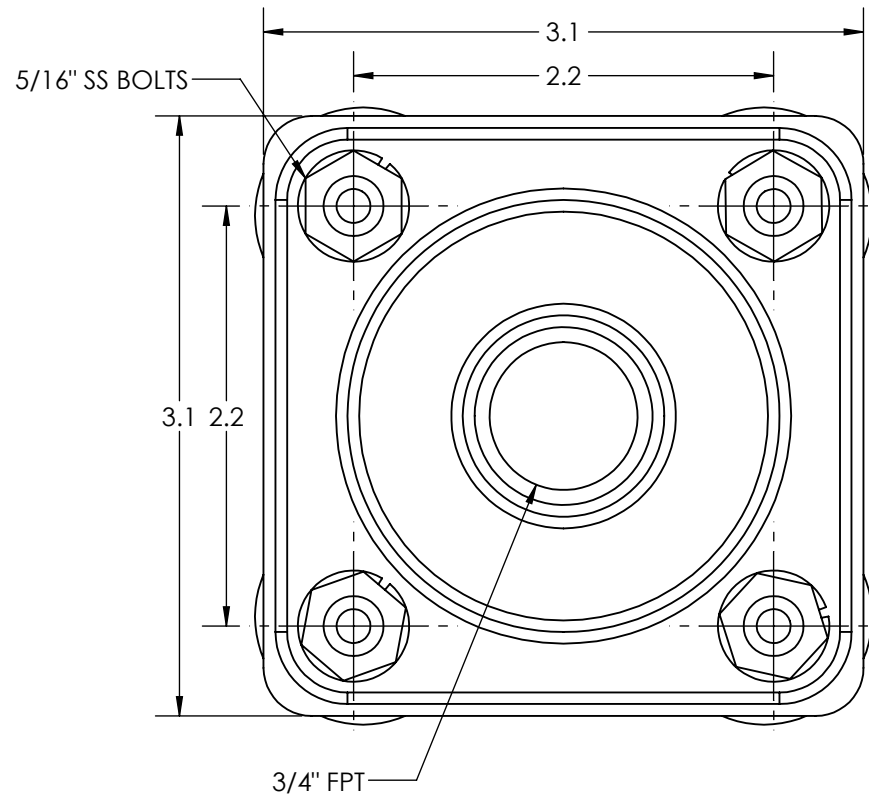
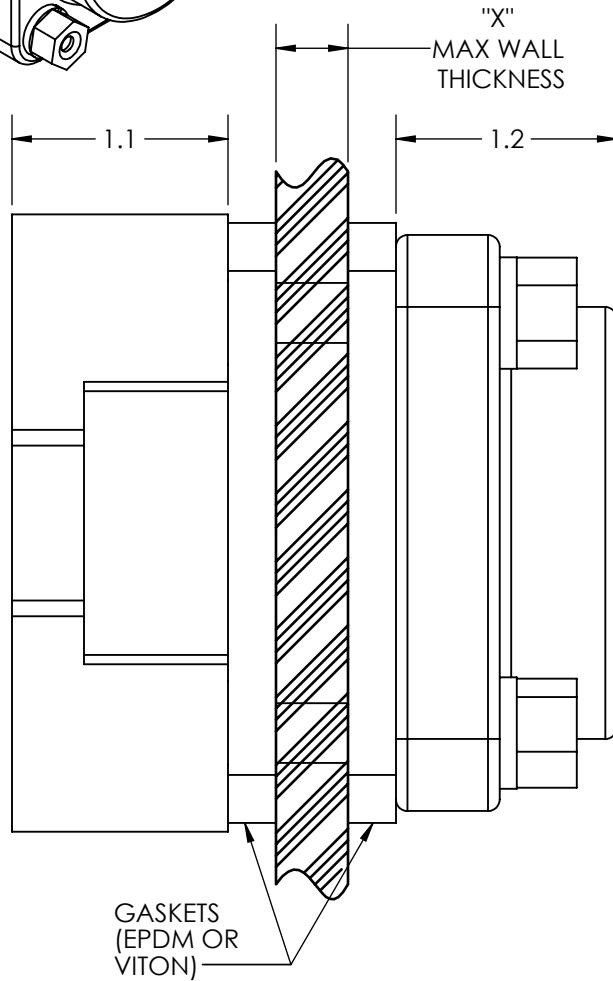

**\*ALL EXTERNAL PIPING MUST BE INDEPENDENTLY SUPPORTED.**  
**\*ONLY BASE FITTINGS TO BE LEFT INSTALLED AT TIME OF SHIPMENT PER SII PROCEDURE.**  
**\*Consult Snyder's Guidelines for Use and Installation prior to delivery.**  
 Available on-line at <http://www.snyderindustriestanks.com/Technical>  
**ALL DIMENSIONS ARE IN INCHES, NOMINAL, & SUBJECT TO CHANGE WITHOUT NOTICE.**  
**ALL DIMENSIONS ON ROTATIONAL MOLDED PARTS ARE SUBJECT TO A ± 3% TOLERANCE.**

DO NOT SCALE	
STATUS:	<b>Released</b>
© TANK HOLDING, CORP, 2025	
<small>ALL DIMENSIONS, DESIGNS, AND INFORMATION ON THIS PRINT MUST BE CONSIDERED PROPRIETARY TO TANK HOLDING, CORP. AND MAY NOT BE USED, COPIED, OR DISTRIBUTED WITHOUT WRITTEN PERMISSION OF AN OFFICER (OR HIS AGENT) OF THE FIRM.</small>	

[www.tankholding.com](http://www.tankholding.com)

TITLE:	<b>FTG PP 3/4 X1IN BLTD</b>	REVISION	<b>A</b>
PART NO.	<b>SEE CHART</b>	SHEET	1 OF 1
ENG. ID.	<b>D013533</b>		