

PART NUMBER	GASKET MATERIAL	BOLT LENGTH	DIM. "X"
34100120	EPDM	SHORT	.5938"
34701110	VITON	SHORT	.5938"

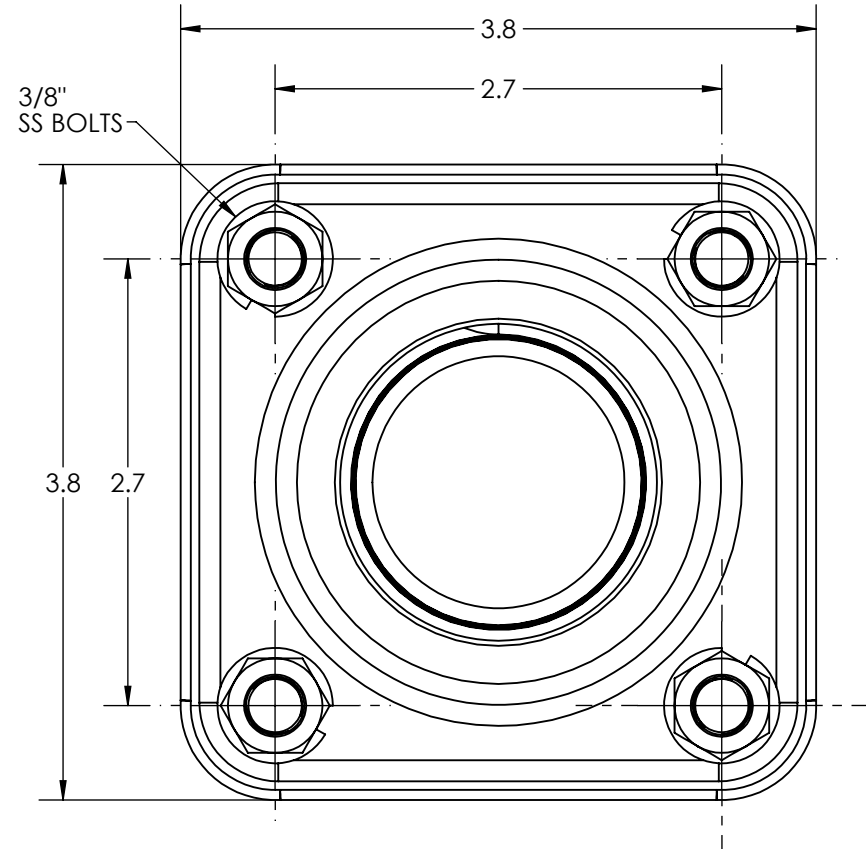
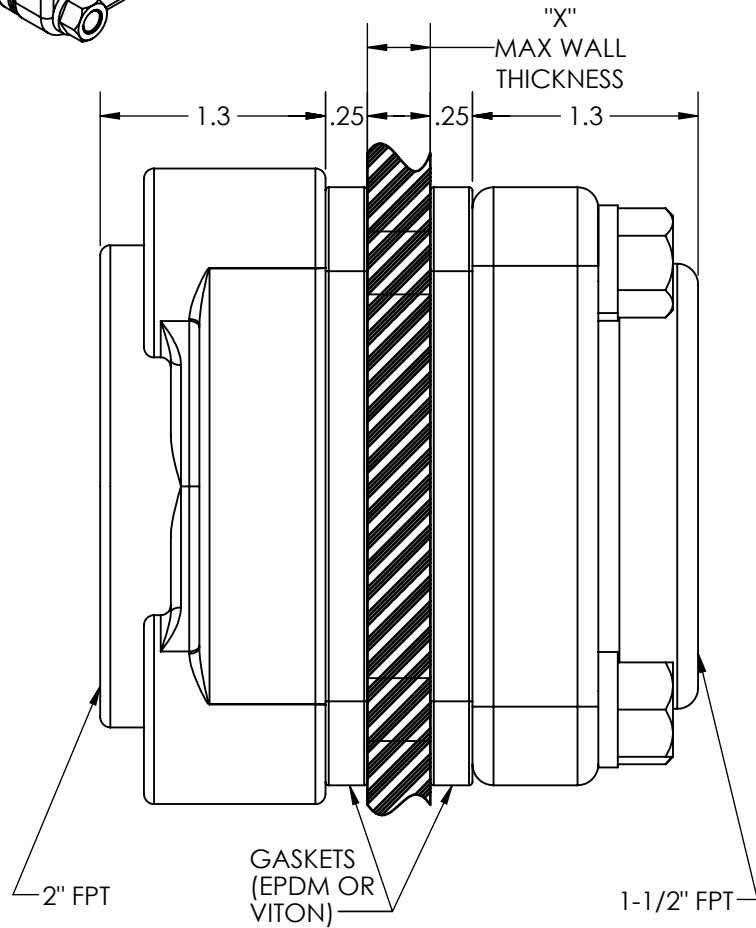

***ALL EXTERNAL PIPING MUST BE INDEPENDENTLY SUPPORTED.**
***ONLY BASE FITTINGS TO BE LEFT INSTALLED AT TIME OF SHIPMENT PER SII PROCEDURE.**
***Consult Snyder's Guidelines for Use and Installation prior to delivery.**
 Available on-line at <http://www.snyderindustriestanks.com/Technical>
ALL DIMENSIONS ARE IN INCHES, NOMINAL, & SUBJECT TO CHANGE WITHOUT NOTICE.
ALL DIMENSIONS ON ROTATIONAL MOLDED PARTS ARE SUBJECT TO A ± 3% TOLERANCE.

DO NOT SCALE		TITLE: FITTING PP 1-1/2 X 2 BLTD		REVISION
STATUS: Released		 www.tankholding.com		A
© TANK HOLDING, CORP, 2025				SHEET
ALL DIMENSIONS, DESIGNS, AND INFORMATION ON THIS PRINT MUST BE CONSIDERED PROPRIETARY TO TANK HOLDING, CORP. AND MAY NOT BE USED, COPIED, OR DISTRIBUTED WITHOUT WRITTEN PERMISSION OF AN OFFICER (OR HIS AGENT) OF THE FIRM.		PART NO. SEE CHART	ENG. ID. D013531	1 OF 1