

- \*SHOWN WITH:
- 28 CUBIC FOOT CAPACITY
  - 22" SANITARY MANWAY
  - 8" FLANGED OUTLET

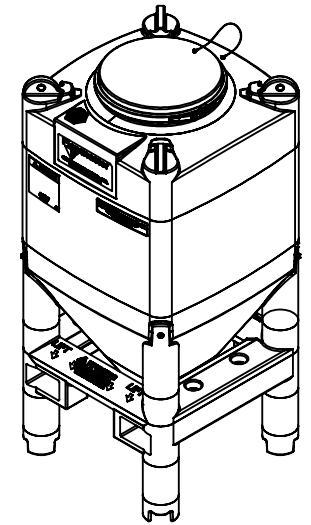

- ADDITIONAL OPTIONS:
- SANITARY FINISH PROCESS
  - CUSTOM MARKINGS
  - CUSTOM LOGO
  - PROTECTIVE WRAP

ADDITIONAL COMPONENTS		
QTY	P/N	DESCRIPTION

ALL DIMENSIONS ARE IN INCHES, NOMINAL, & SUBJECT TO CHANGE WITHOUT NOTICE.  
 ALL DIMENSIONS ON ROTATIONAL MOLDED PARTS ARE SUBJECT TO A ± 3% TOLERANCE.

DO NOT SCALE		DRAWN BY	 <b>SNYDER INDUSTRIES</b> A BRAND OF TANK HOLDING CORP.	TITLE:	REVISION
STATUS: <b>Released</b>		IGG		<b>60° 36X36 DRY HANDLING FLOWMASTER</b>	<b>A</b>
© TANK HOLDING, CORP, 2022			(402) 467-5221 www.snydernet.com	PART NO.	ENG. ID.
<small>ALL DIMENSIONS, DESIGNS, AND INFORMATION ON THIS PRINT MUST BE CONSIDERED PROPRIETARY TO TANK HOLDING, CORP. AND MAY NOT BE USED, COPIED, OR DISTRIBUTED WITHOUT WRITTEN PERMISSION OF AN OFFICER (OR HIS AGENT) OF THE FIRM.</small>					<b>D011957</b>