

BOTTLE LOGO PLATE TO READ:

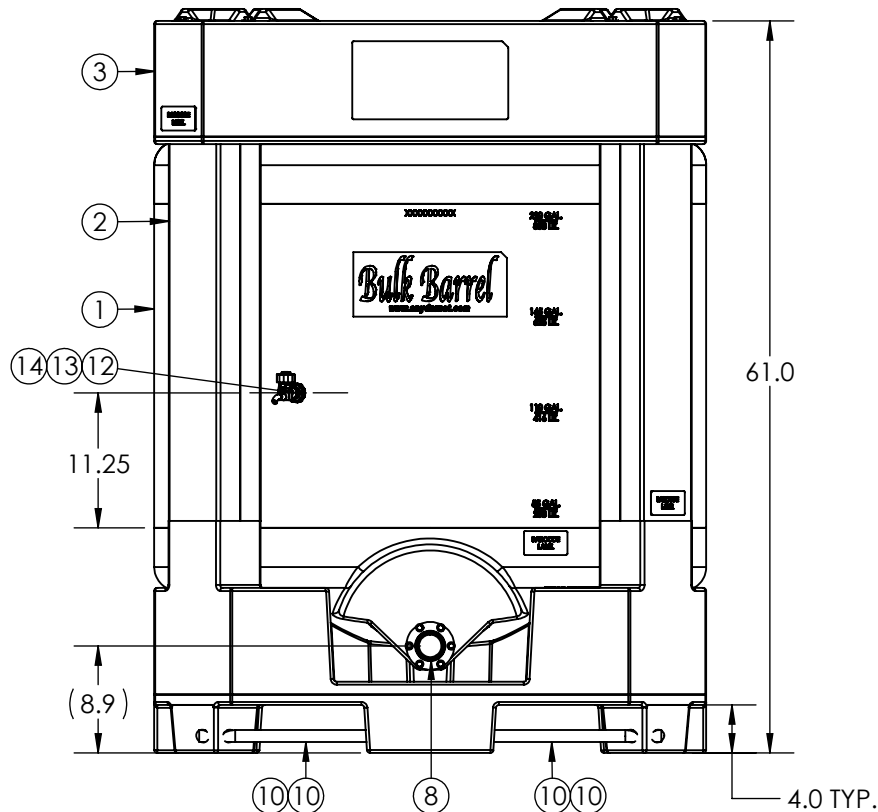

(15) (16) (17) (18) ITEMS ARE SHIPPED LOOSE

300 GALLON BULK BARREL "STANDARD EQUIPMENT PACKAGE"



18	2	33100761	GASKET 2IN EPDM WHITE FDA SANITARY
17	2	35300681	CLAMP 2IN SS SANITARY TRI-C
16	1	35300678	END CAP 2IN SS SANITARY TRI-C
15	1	35400251	VALVE 2IN BF SS/SILICONE TRI-C
14	1	33100764	GASKET EPDM FDA 1.55 X 1.05 X 1/4IN 40D
13	1	35902097	SAMPLE TAP 3/8IN MPT 316SS #F38303SS
12	1	35300683	FTG 3/8IN SS BH BJO #TF038SS
11	1	99600036	BAG PE 47 X 47 X 75IN X 2.0ML CLR
10	2	34700766	ASM TEETER BAR - ULTRATAINER FRONT/BACK
9	1	34700905	ASM PIN PURCH PLASTIC W/BOLTS-ULTRA
8	1	34701539	ASM FTG 2IN SS WELDED FERRULE EPDM WHITE
7	1	33100784	GASKET FULL WRAP 30GAL DRUM FDA SILICONE
6	1	35902393	DRUM RING 22IN DIA 304SS - SS HANDLE
5	1	34300167	FITTING PE 2IN SPIN WELD RASD#65HD
4	1	34701541	ASM PLUG 2IN NPS BUNG EPDM WHITE FDA
3	1	6700021B85801	ASM TOP PRO ULT HD/WINE NO LOGO
2	1	6860000B85801	ASM BASE 275 ULT HD/WINE
1	1	6040048B97200	TK 300G BULK BARREL NUN 2IN FLG OUT

ITEM NO.	QTY.	PART NUMBER	DESCRIPTION
DO NOT SCALE		DRAWN BY	
STATUS: Released		SB	
© SNYDER INDUSTRIES, LLC, 2021		 SNYDER INDUSTRIES (402) 467-5221 www.snydernet.com	
<small>TOLERANCES UNLESS OTHERWISE SPECIFIED: ANGULAR = ±1/2° FRACTIONAL = ±1/16" X = ±0.1", XX = ±.03", XXX = ±.010"</small>		PART NO.	ENG. ID.
		6040048B97200	D008318
ASM TK 300G BULK BARREL 2IN VALVE W/TAP			REVISION A SHEET 1 OF 1