

PART NUMBER	GASKET MATERIAL	BOLT LENGTH	DIM. "X"
34100103	EPDM	SHORT	.75"
34701111	VITON	SHORT	.75"
34100133	EPDM	LONG	1.00"
34701445	VITON	LONG	1.00"

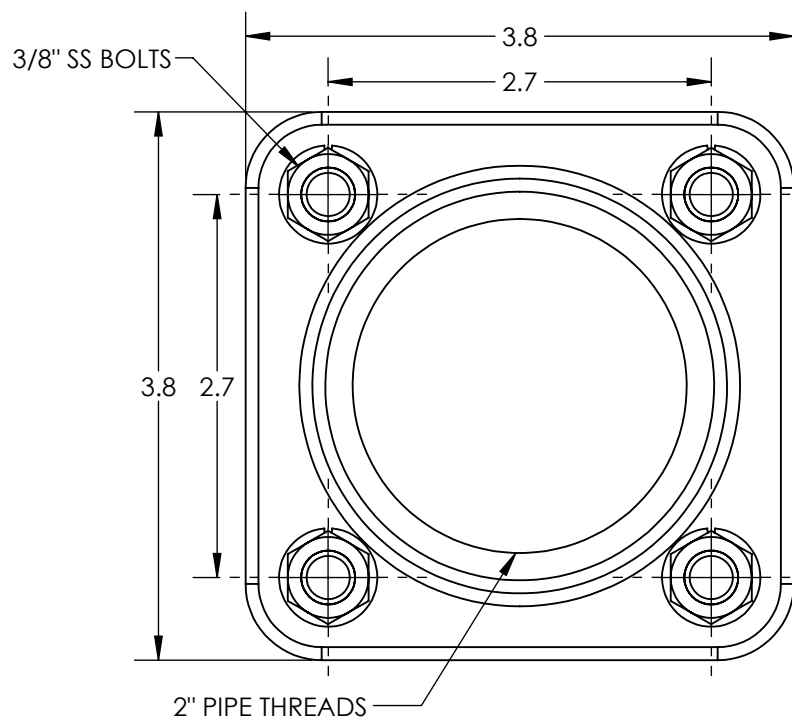
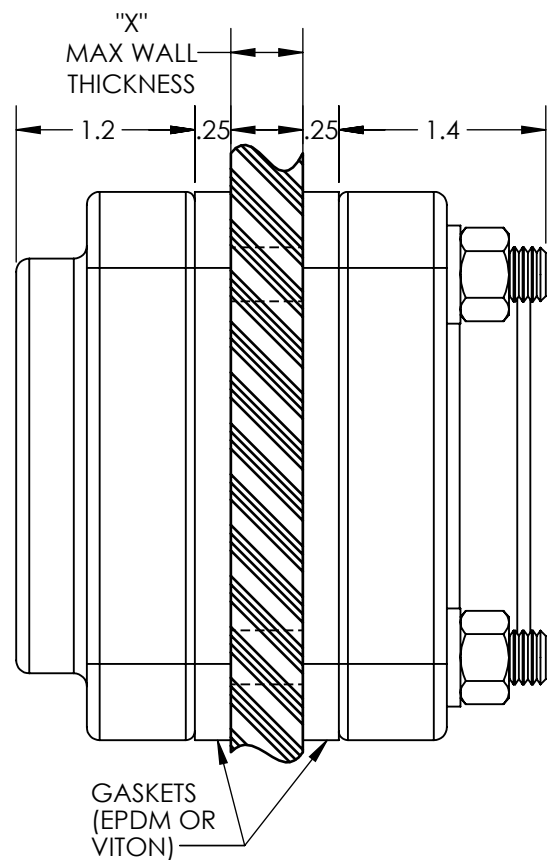

**\*ALL EXTERNAL PIPING MUST BE INDEPENDENTLY SUPPORTED.**  
**\*ONLY BASE FITTINGS TO BE LEFT INSTALLED AT TIME OF SHIPMENT PER SII PROCEDURE.**  
**\*Consult Snyder's Guidelines for Use and Installation prior to delivery.**  
 Available on-line at <http://www.snyderindustriestanks.com/Technical>  
**ALL DIMENSIONS ARE IN INCHES, NOMINAL, & SUBJECT TO CHANGE WITHOUT NOTICE.**  
**ALL DIMENSIONS ON ROTATIONAL MOLDED PARTS ARE SUBJECT TO A ± 3% TOLERANCE.**

DO NOT SCALE

STATUS: **Released**

© TANK HOLDING, CORP, 2025

ALL DIMENSIONS, DESIGNS, AND INFORMATION ON THIS PRINT MUST BE CONSIDERED PROPRIETARY TO TANK HOLDING, CORP. AND MAY NOT BE USED, COPIED, OR DISTRIBUTED WITHOUT WRITTEN PERMISSION OF AN OFFICER (OR HIS AGENT) OF THE FIRM.



TITLE: **FTG PP 2IN BLTD**

REVISION: **B**

SHEET: 1 OF 1

PART NO.: **SEE CHART**

ENG. ID.: **D001665**