

| ASSEMBLY PART NO. | | | 34700773 | 34700787 | 34700774 | 34700783 | 34702285 |
|-------------------|------|---------------------------|----------|----------|-----------|----------|----------|
| INSERT MATERIAL | | | 316 SS | | HASTELLOY | TITANIUM | |
| # | QTY. | DESCRIPTION | VITON | EPDM | VITON | VITON | EPDM |
| 1 | 1 | 4" PVC SUMO ADAPTER | 35900482 | 35900482 | 35900482 | 35900482 | 35900482 |
| | | **OR CPVC SUMO ADAPTER | 35900512 | 35900512 | 35900512 | 35900512 | 35900512 |
| 2 | 1 | O-RING, STYLE 345 (3/16") | 33100168 | 33100175 | 33100168 | 33100168 | 33100175 |
| 3 | 1 | O-RING, STYLE 346 (3/16") | 33100169 | 33100176 | 33100169 | 33100169 | 33100176 |

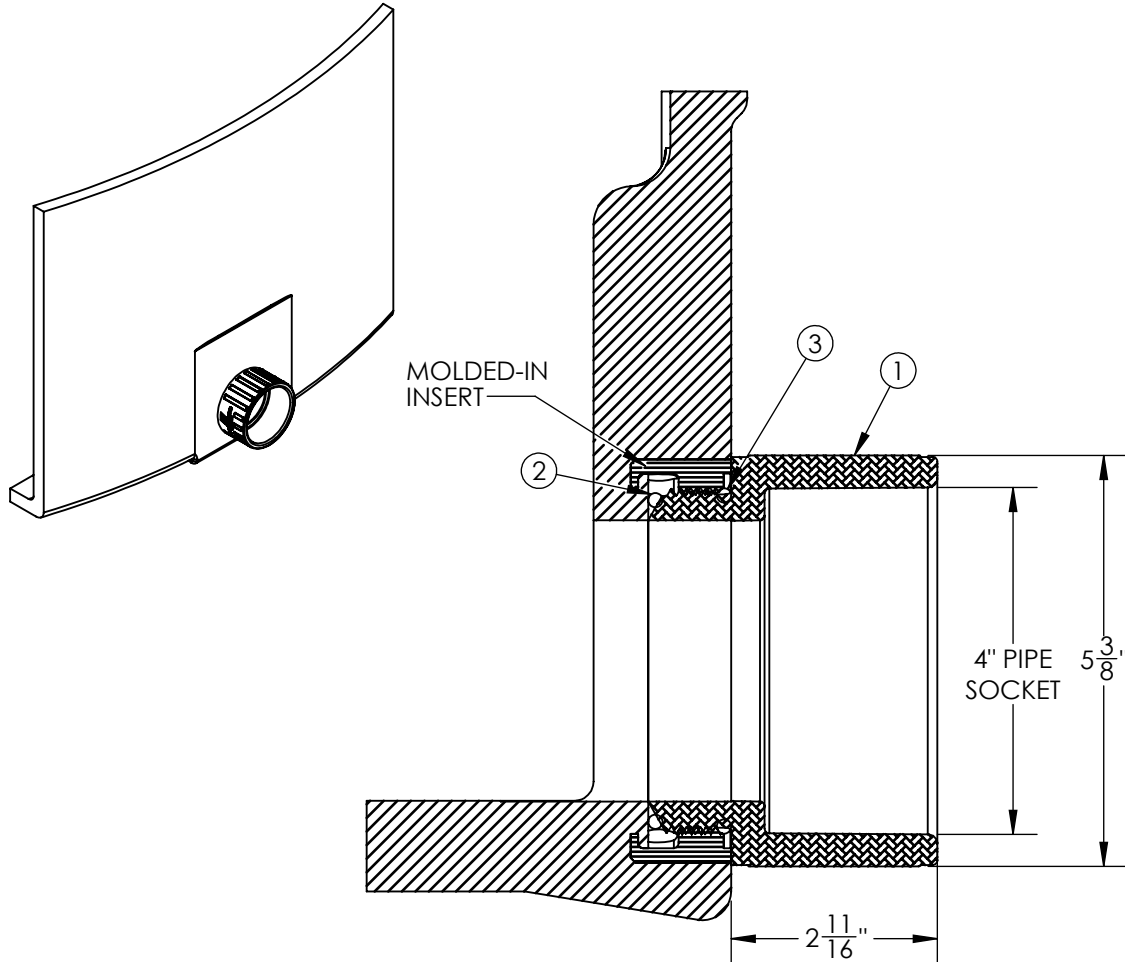

SHIPPING NOTES:

- SUMO SHIPPING STABILIZER SHOULD BE INSTALLED PRIOR TO MOVING CONTAINER WITH SUMO FITTING.
- NEVER MOVE CONTAINER WITH PVC FITTING INSTALLED UNLESS APPROVED BY SII ENGINEERING.

INSTALLATION NOTES:

- ONCE TANK IS PLACED ON SITE, REMOVE SHIPPING STABILIZER.
- CLEAN THREADS & O-RING SEATS.
- INSTALL SMALLER O-RING INSIDE SUMO MOLDED-IN FITTING.
- CAREFULLY STRETCH LARGER O-RING ENOUGH TO INSTALL IT INTO THE O-RING GROOVE ON THE ADAPTER.
- O-RING MAY BE LUBRICATED WITH SUITABLE LUBRICANT (ex. WATER)
- SCREW ADAPTER IN UNTIL THE STEP IN THE ADAPTER IS FLUSH WITH THE TANK WALL. DO NOT OVER-TORQUE (25 FT-LBs OF TORQUE MAX.)
- ONCE SUMO ADAPTER IS INSTALLED, PIPING OR OTHER FITTINGS MAY BE CONNECTED TO THE ADAPTER. A UNION OR BOLTED FITTING WITH SUITABLE FLEXIBLE CONNECTION SHOULD BE INSTALLED AS CLOSE TO THE TANK AS POSSIBLE TO ALLOW FOR FUTURE DISASSEMBLY.

***ALL EXTERNAL PIPING MUST BE INDEPENDENTLY SUPPORTED.**
***ONLY BASE FITTINGS TO BE LEFT INSTALLED AT TIME OF SHIPMENT PER SII PROCEDURE.**
***TANKS ORDERED WITH FOAM INSULATION WILL HAVE AN INCREASED DIAMETER OF 4-6 INCHES.**
***Consult Snyder's Guidelines for Use and Installation prior to delivery.**
 Available on-line at <http://www.snyderindustriestanks.com/Technical>
ALL DIMENSIONS ARE IN INCHES, NOMINAL, & SUBJECT TO CHANGE WITHOUT NOTICE.
ALL DIMENSIONS ON ROTATIONAL MOLDED PARTS ARE SUBJECT TO A ± 3% TOLERANCE.

| | | | | | |
|--|--|----------|--|---|-----------------|
| DO NOT SCALE | | DRAWN BY | A BRAND OF TANK HOLDING CORP. | TITLE: | REVISION |
| STATUS: Released | | SB | | INSTRUCTIONS ASSEMBLY 4IN SUMO | A |
| © TANK HOLDING, CORP, 2022 | | | (402) 467-5221 www.snyder.net | PART NO. | ENG. ID. |
| <small>ALL DIMENSIONS, DESIGNS, AND INFORMATION ON THIS PRINT MUST BE CONSIDERED PROPRIETARY TO TANK HOLDING, CORP. AND MAY NOT BE USED, COPIED, OR DISTRIBUTED WITHOUT WRITTEN PERMISSION OF AN OFFICER (OR HIS AGENT) OF THE FIRM.</small> | | | | 99800054 | 99800054 |
| | | | | SHEET | 1 OF 1 |