

PART NUMBER	DESCRIPTION	GASKET MATERIAL
34702555	FTG PP 4IN BLTD TXT ENCAP SLB/VIT	VITON
34700647	FTG PP 4IN BLTD TXT ENCAP SLB/EPDM	EPDM

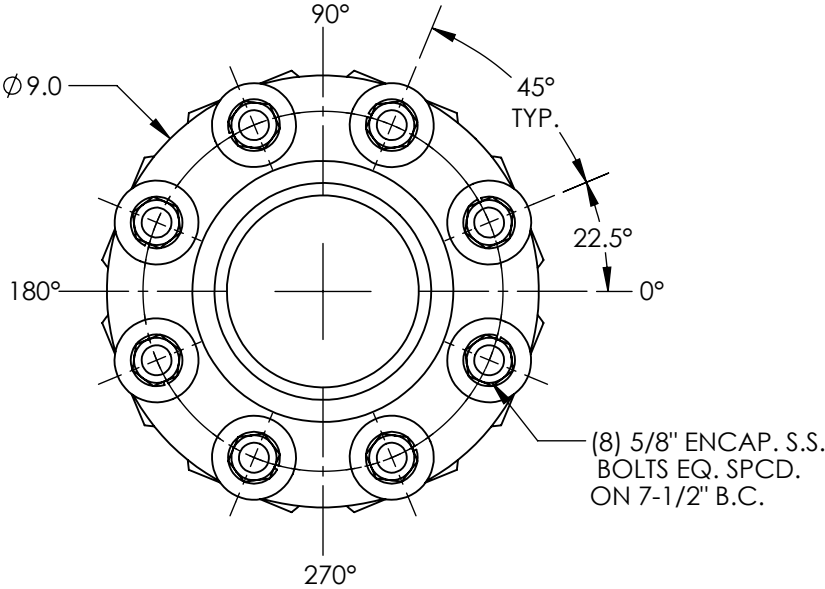
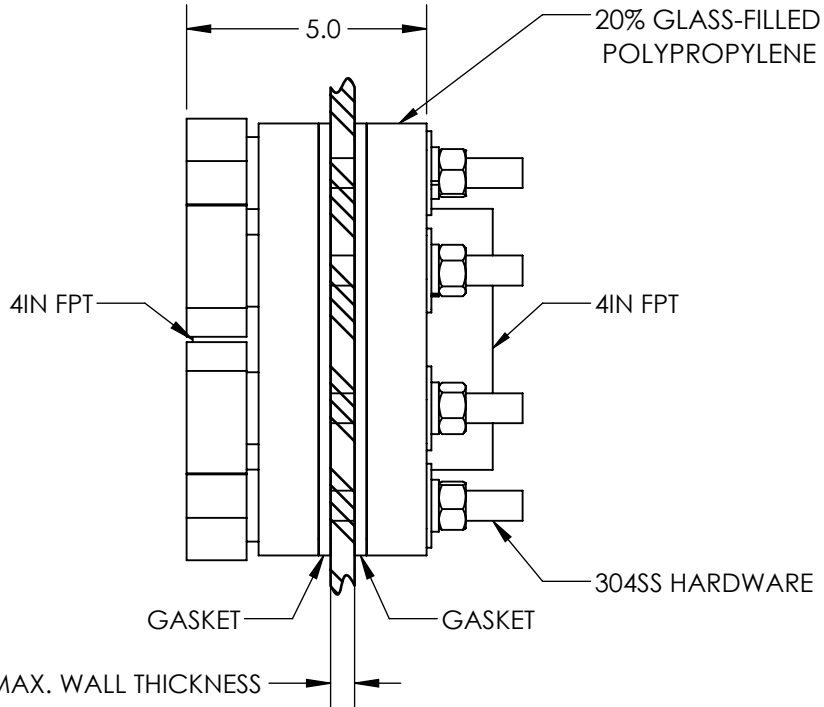
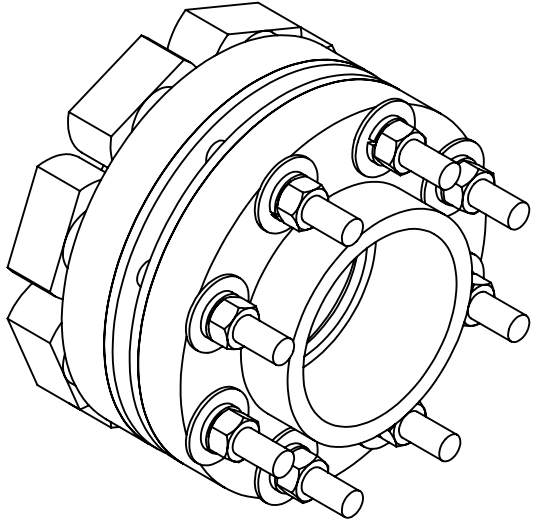

ALL DIMENSIONS ARE IN INCHES, NOMINAL, & SUBJECT TO CHANGE WITHOUT NOTICE.  
 ALL DIMENSIONS ON ROTATIONAL MOLDED PARTS ARE SUBJECT TO A ± 3% TOLERANCE.

DO NOT SCALE	DRAWN BY	TITLE:	REVISION
Released	BH	FTG PP 4IN BLTD TXT	A
© SNYDER INDUSTRIES, LLC, 2020			SHEET
ALL DIMENSIONS, DESIGNS, AND INFORMATION ON THIS PRINT MUST BE CONSIDERED PROPRIETARY TO SNYDER INDUSTRIES, LLC, AND MAY NOT BE USED, COPIED, OR DISTRIBUTED WITHOUT WRITTEN PERMISSION OF AN OFFICER (OR HIS AGENT) OF THE FIRM.		PART NO.	1 OF 1
[402] 467-5221 www.snyder.net		SEE CHART	D010966