

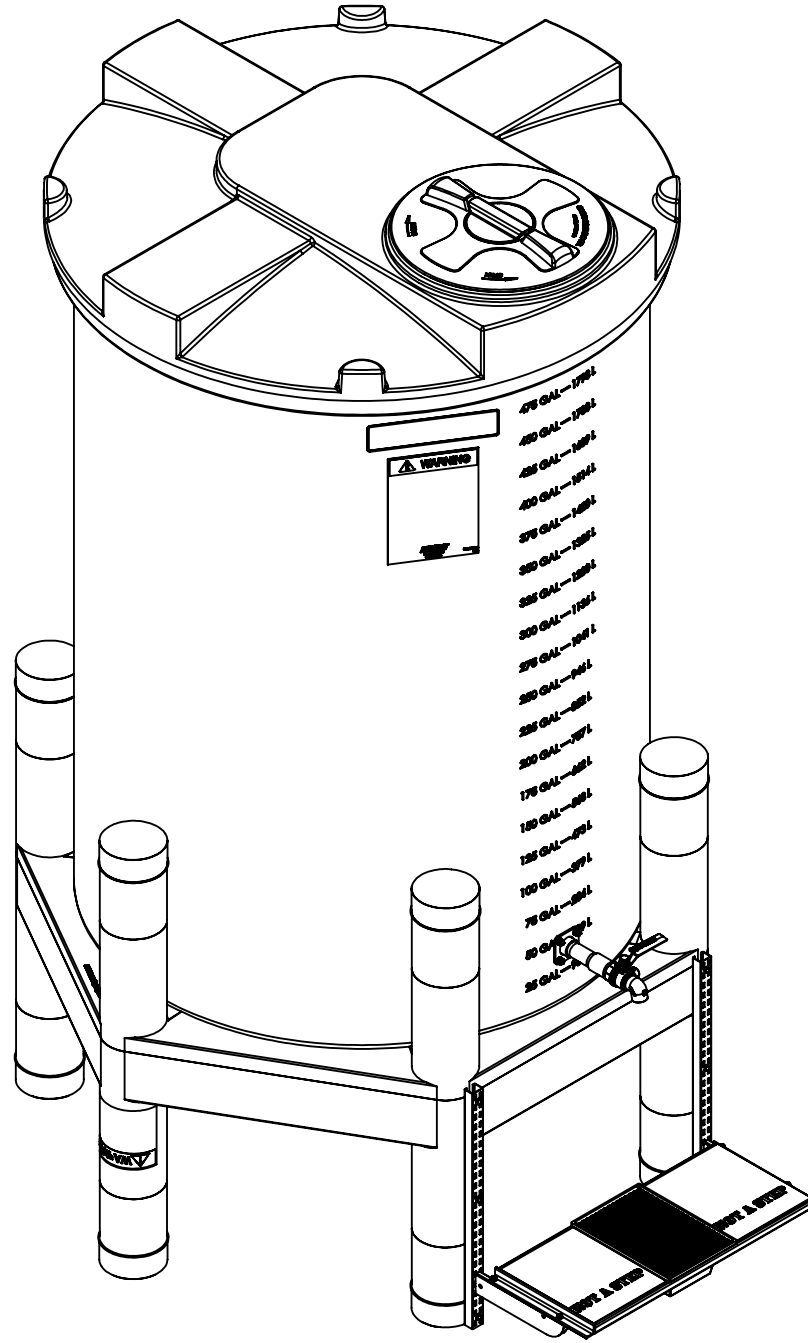

**TOOLS NEEDED:**

- 5/32 DRILL BIT
- TEFLON PASTE OR TAPE
- PHILLIPS HEAD SCREWDRIVER
- 16MM DEEP SOCKET
- 1/2" SOCKET
- 1" OPEN END WRENCH OR CRESCENT WRENCH



**INSTRUCTIONS:**

1. THE FOLLOWING INSTRUCTIONS ARE FOR INSTALLING THE DRIP TRAY ASSEMBLY TO A TANK AND STAND.

DO NOT SCALE		DRAWN BY		 <b>STI SNYDER INDUSTRIES</b> (402) 467-5221 www.snydernet.com	TITLE:	<b>INSTRUCTIONS FOR LUBE DRIP TRAY PLY STAND</b>	REVISION	
STATUS:	<b>Released</b>	KB					<b>A</b>	
© SNYDER INDUSTRIES, LLC, 2020					PART NO.	<b>99800112</b>	ENG. ID.	<b>D010895</b>
ALL DIMENSIONS, DESIGNS, AND INFORMATION ON THIS PRINT MUST BE CONSIDERED PROPRIETARY TO SNYDER INDUSTRIES, LLC, AND MAY NOT BE USED, COPIED, OR DISTRIBUTED WITHOUT WRITTEN PERMISSION OF AN OFFICER (OR HIS AGENT) OF THE FIRM.				TOLERANCES UNLESS OTHERWISE SPECIFIED: ANGULAR = ±1/2° FRACTIONAL = ±1/16" .X = ±0.1", .XX = ±.03", .XXX = ±.010"				SHEET 1 OF 5

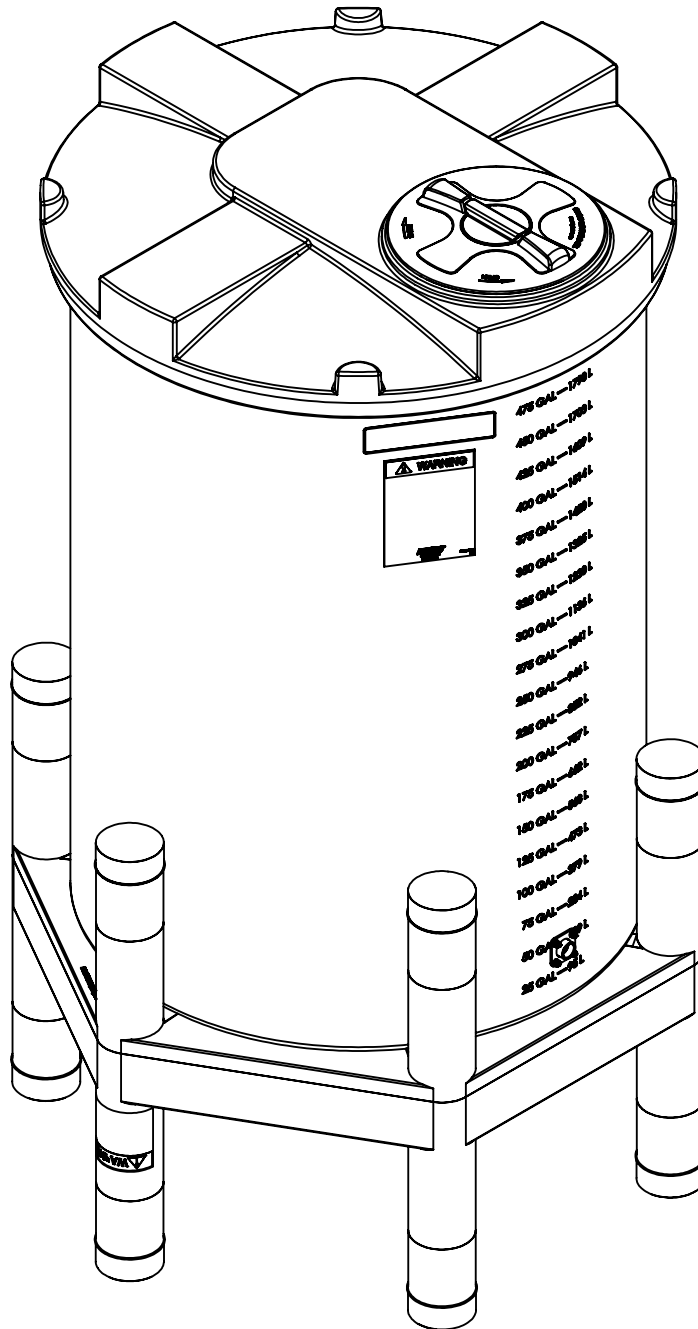

**INSTRUCTIONS:**

1. MAKE SURE THAT FLAT SIDE IS UP ON STAND.
2. PLACE TANK ON STAND IN THE ORIENTATION SHOWN.

DO NOT SCALE		DRAWN BY		 (402) 467-5221 <a href="http://www.snydernet.com">www.snydernet.com</a>	TITLE:		REVISION
STATUS:		KB			<b>INSTRUCTIONS FOR LUBE DRIP TRAY PLY STAND</b>		<b>A</b>
© SNYDER INDUSTRIES, LLC, 2020				<small>           TOLERANCES UNLESS OTHERWISE SPECIFIED:            ANGULAR = ±1/2°            FRACTIONAL = ±1/16"            .X = ±0.1", .XX = ±.03", .XXX = ±.010"         </small>		PART NO.	ENG. ID.
						<b>99800112</b>	<b>D010895</b>
<small>           ALL DIMENSIONS, DESIGNS, AND INFORMATION ON THIS PRINT MUST BE CONSIDERED PROPRIETARY TO SNYDER INDUSTRIES, LLC, AND MAY NOT BE USED, COPIED, OR DISTRIBUTED WITHOUT WRITTEN PERMISSION OF AN OFFICER (OR HIS AGENT) OF THE FIRM.         </small>							<small>           SHEET 2 OF 5         </small>

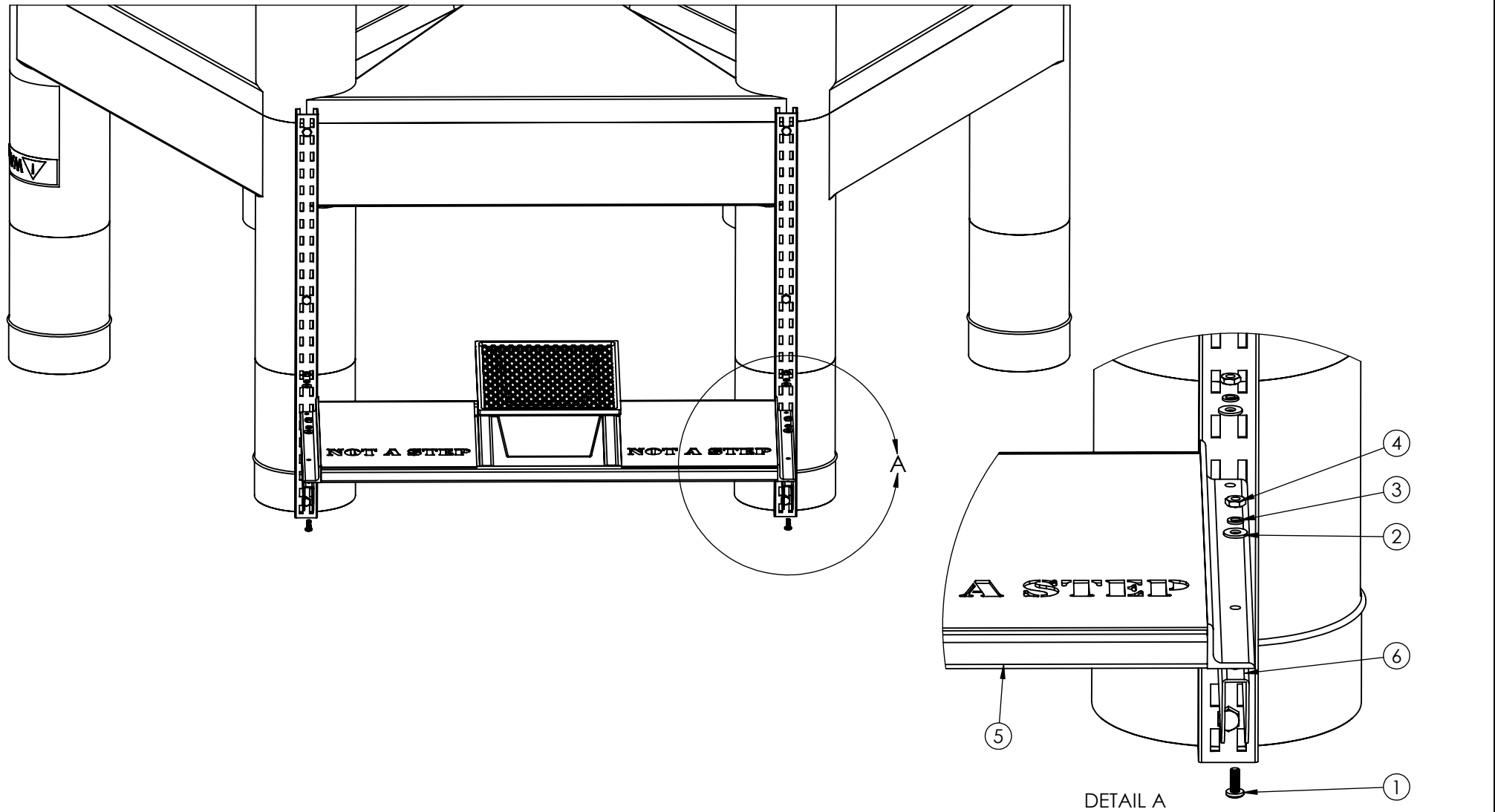

DETAIL A

6	2	35902478	BRACKET POWERQUEST TANK
5	1	34902160	DRIP TRAY HOLDER 360/440/500 VFT
4	4	35100914	NUT #10-24 HH ZP CS
3	4	35100655	WASHER SPRING LOCK #10 SS
2	4	35100725	WASHER #10 FLAT ZP
1	4	35200248	SCREW #10 X 1/2LG PH ZP

ITEM NO.	QTY.	PART NUMBER	DESCRIPTION
DO NOT SCALE		DRAWN BY	<p><b>SNYDER INDUSTRIES</b> (402) 467-5221 www.snydernet.com</p>
STATUS: <b>Released</b>		KB	
© SNYDER INDUSTRIES, LLC, 2020			
<small>ALL DIMENSIONS, DESIGNS, AND INFORMATION ON THIS PRINT MUST BE CONSIDERED PROPRIETARY TO SNYDER INDUSTRIES, LLC, AND MAY NOT BE USED, COPIED, OR DISTRIBUTED WITHOUT WRITTEN PERMISSION OF AN OFFICER (OR HIS AGENT) OF THE FIRM.</small>			<small>TOLERANCES UNLESS OTHERWISE SPECIFIED: ANGULAR = ±1/2° FRACTIONAL = ±1/16" .X = ±0.1", .XX = ±.03", .XXX = ±.010"</small>
TITLE: <b>INSTRUCTIONS FOR LUBE DRIP TRAY PLY STAND</b>		PART NO. <b>99800112</b>	ENG. ID. <b>D010895</b>
REVISION <b>A</b>			SHEET 3 OF 5

INSTRUCTIONS:  
3. ASSEMBLE DRIP TRAY HOLDER (5) TO BRACKETS (6) USING PROVIDED HARDWARE.

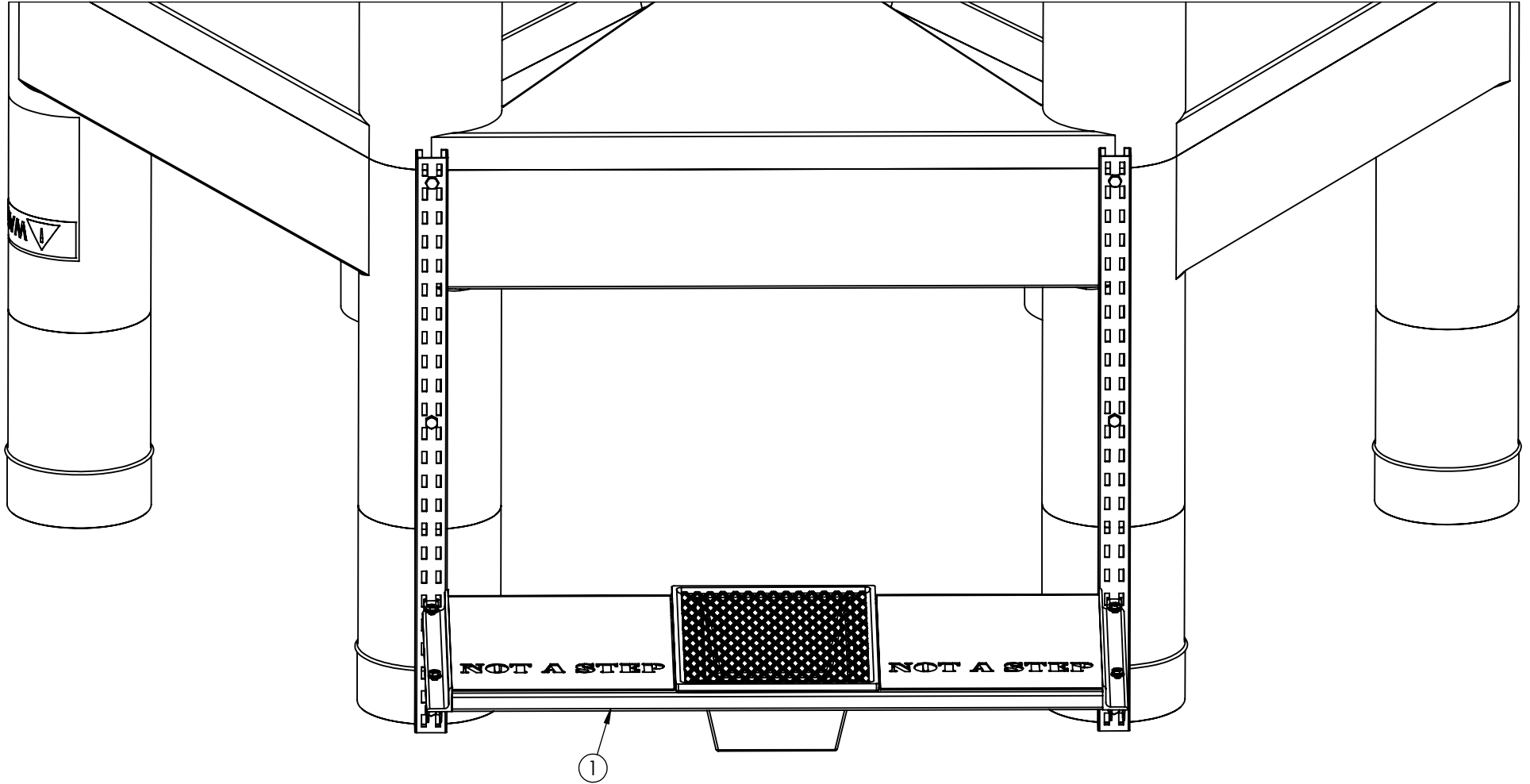

INSTRUCTIONS:

4. HOOK ASSEMBLED DRIP TRAY IN TO PROVIDED LEG BRACKETS AS SHOWN.

1	1	34902160	DRIP TRAY HOLDER 360/440/500 VFT	
ITEM NO.	QTY.	PART NUMBER	DESCRIPTION	
DO NOT SCALE		DRAWN BY	 <b>SNYDER INDUSTRIES</b> (402) 467-5221 www.snydernet.com	REVISION
STATUS: <b>Released</b>		KB		<b>INSTRUCTIONS FOR LUBE DRIP TRAY PLY STAND</b>
© SNYDER INDUSTRIES, LLC, 2020			TOLERANCES UNLESS OTHERWISE SPECIFIED: ANGULAR = ±1/2° FRACTIONAL = ±1/16" .X = ±0.1", .XX = ±.03", .XXX = ±.010"	SHEET
			PART NO.	4 OF 5
			<b>99800112</b>	<b>D010895</b>

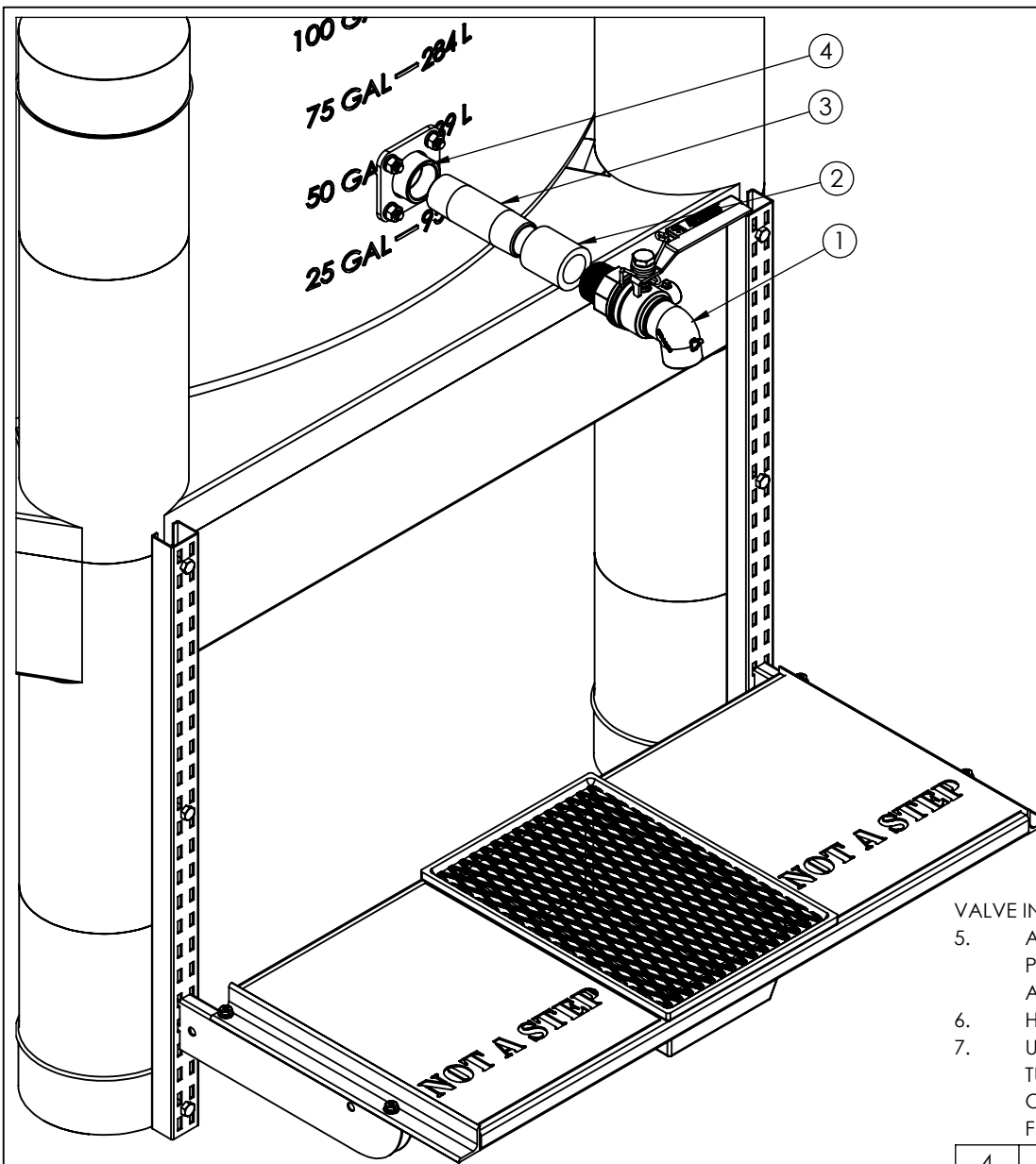

VALVE INSTALATION INSTRUCTIONS:

5. ALL THREADED FITTINGS MUST BE COATED WITH SUFFICIENT PIPE THREAD SEALANT TO PREVENT LEAKAGE. SNYDER RECOMMENDS TRU-BLU THREAD SEALANT WITH TEFLON FOR ALL APPLICATIONS.
6. HAND TIGHTEN NIPPLE, COUPLER, AND VALVE TOGETHER.
7. USING 1" WRENCH, TIGHTEN ENTIRE SERIES BY TURNING THE VALVE 4-6 TURNS AND STOP TURNING WHEN VALVE IS VERTICAL AND JOINTS ARE TIGHT. IF NOT SATISFIED WITH VALVE ORIENTATION THEN BACK OFF THE SERIES OF COMPONENTS AT WHATEVER JOINT LOOSENS FIRST, REAPPLY SEALANT AND RETIGHTEN UNTIL VALVE ORIENTATION IS VERTICAL.

4	1	34702846	ASM 1IN BLTD FTG 316SS EPDM SHORT-BOLT
3	1	35301123	NIPPLE 1IN SCH40 X 4LG 304SS TBE
2	1	35300862	COUPLING 1IN FULL 1000LB BARSTK 304SS
1	1	35400419	VLV 1IN BV MPTXSPIG SPRING LD BUNA 316SS

ITEM NO.	QTY.	PART NUMBER	DESCRIPTION
DO NOT SCALE		DRAWN BY	TITLE:
STATUS: Released		KB	<b>INSTRUCTIONS FOR LUBE DRIP TRAY PLY STAND</b>
© SNYDER INDUSTRIES, LLC, 2020		 (402) 467-5221 www.snydernet.com	REVISION <b>A</b>
<small>ALL DIMENSIONS, DESIGNS, AND INFORMATION ON THIS PRINT MUST BE CONSIDERED PROPRIETARY TO SNYDER INDUSTRIES, LLC, AND MAY NOT BE USED, COPIED, OR DISTRIBUTED WITHOUT WRITTEN PERMISSION OF AN OFFICER (OR HIS AGENT) OF THE FIRM.</small>		<small>TOLERANCES UNLESS OTHERWISE SPECIFIED:            ANGULAR = ±1/2°            FRACTIONAL = ±1/16"            .X = ±0.1", .XX = ±.03", .XXX = ±.010"</small>	SHEET 5 OF 5
		PART NO.	ENG. ID.
		<b>99800112</b>	<b>D010895</b>