

OPTIONAL LID SHOWN
(1925410M)

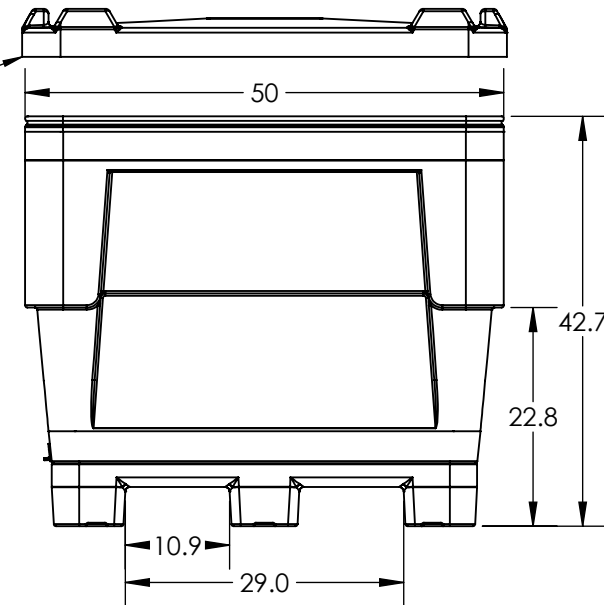
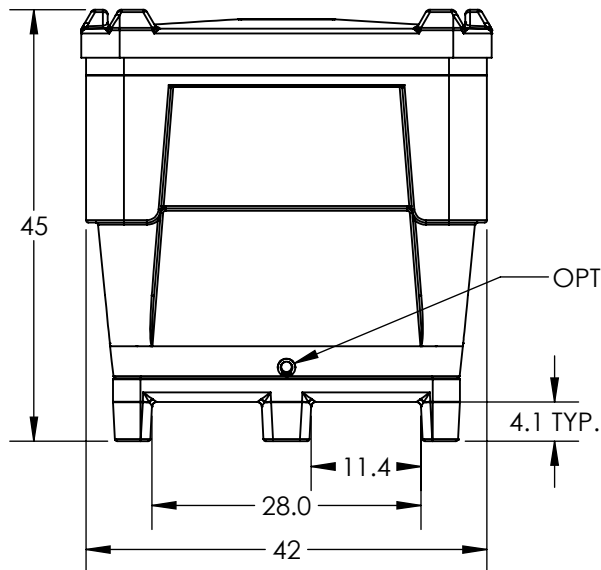

ALL DIMENSIONS ARE IN INCHES, NOMINAL, & SUBJECT TO CHANGE WITHOUT NOTICE.
ALL DIMENSIONS ON ROTATIONAL MOLDED PARTS ARE SUBJECT TO A \pm 3% TOLERANCE.

DO NOT SCALE		DRAWN BY	BONAR PLASTICS www.bonarplastics.com	TITLE:	REVISION
STATUS:	Released	IGG	1005 Atlantic Drive West Chicago, IL 60185 (630)293-0303	ASM BIN 1142 POLYCMBO PB ND	SHEET 1 OF 1
© SNYDER INDUSTRIES, INC., 2018			www.bonarplastics.com	PART NO.	ENG. ID.
ALL DIMENSIONS, DESIGNS, AND INFORMATION ON THIS PRINT MUST BE CONSIDERED PROPRIETARY TO SNYDER INDUSTRIES, INC., AND MAY NOT BE USED, COPIED, OR DISTRIBUTED WITHOUT WRITTEN PERMISSION OF AN OFFICER (OR HIS AGENT) OF THE FIRM.				1928200M	D008648