

**BOTTLE LOGO PLATE TO READ:**

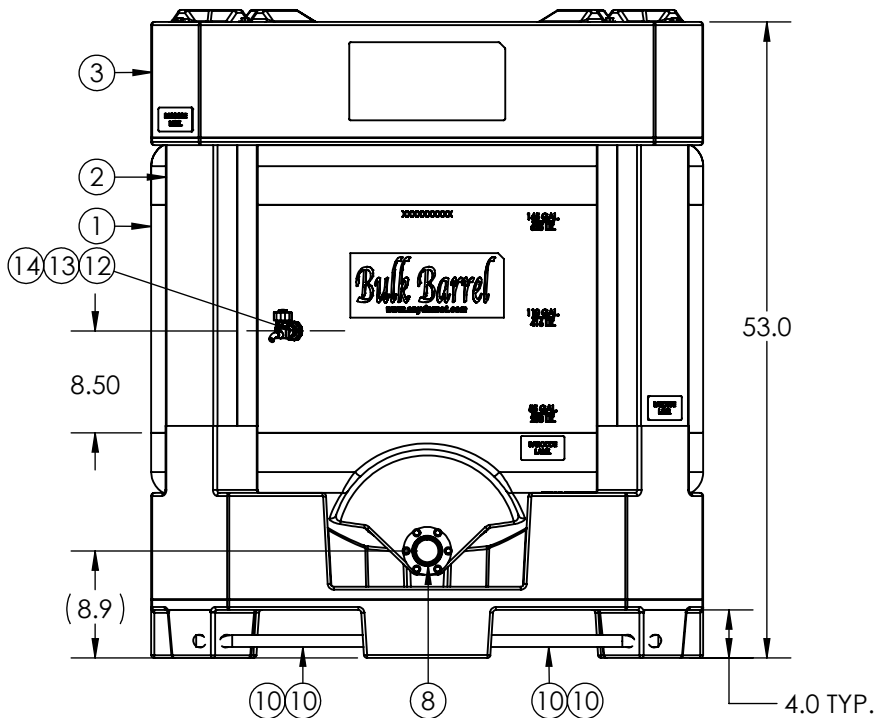

(15) (16) (17) (18) ITEMS ARE SHIPPED LOOSE

**240 GALLON BULK BARREL "STANDARD EQUIPMENT PACKAGE"**



|    |   |               |  |
|----|---|---------------|--|
| 18 | 2 | 33100761      | GASKET 2IN EPDM WHITE FDA SANITARY       |
| 17 | 2 | 35300681      | CLAMP 2IN SS SANITARY TRI-C              |
| 16 | 1 | 35300678      | END CAP 2IN SS SANITARY TRI-C            |
| 15 | 1 | 35400251      | VALVE 2IN BF SS/SILICONE TRI-C           |
| 14 | 1 | 33100764      | GASKET EPDM FDA 1.55 X 1.05 X 1/4IN 40D  |
| 13 | 1 | 35902097      | SAMPLE TAP 3/8IN MPT 316SS #F38303SS     |
| 12 | 1 | 35300683      | FTG 3/8IN SS BH BJO #TF038SS             |
| 11 | 1 | 99600036      | BAG PE 47 X 47 X 75IN X 2.0ML CLR        |
| 10 | 2 | 34700766      | ASM TEETER BAR - ULTRATAINER FRONT/BACK  |
| 9  | 1 | 34700905      | ASM PIN PURCH PLASTIC W/BOLTS-ULTRA      |
| 8  | 1 | 34701539      | ASM FTG 2IN SS WELDED FERRULE EPDM WHITE |
| 7  | 1 | 33100784      | GASKET FULL WRAP 30GAL DRUM FDA SILICONE |
| 6  | 1 | 35902393      | DRUM RING 22IN DIA 304SS - SS HANDLE     |
| 5  | 1 | 34300167      | FITTING PE 2IN SPIN WELD RASD#65HD       |
| 4  | 1 | 34701541      | ASM PLUG 2IN NPS BUNG EPDM WHITE FDA     |
| 3  | 1 | 6700021B85801 | ASM TOP PRO ULT HD/WINE NO LOGO          |
| 2  | 1 | 6850000B85801 | ASM BASE 220 ULT HD/WINE                 |
| 1  | 1 | 6820053B97200 | TK 240G BULK BARREL NUN 2IN FLG OUT      |

| ITEM NO.   | QTY. | PART NUMBER   | DESCRIPTION                                    |
|--|------|---|--|
| DO NOT SCALE   |      | DRAWN BY  |  |
| STATUS: <b>Released</b>  |      | SB  |  |
| © SNYDER INDUSTRIES, LLC, 2021   |      | (402) 467-5221<br>www.snydernet.com   | <b>ASM TK 240G BULK BARREL 2IN VALVE W/TAP</b> |
| <small>ALL DIMENSIONS, DESIGNS, AND INFORMATION ON THIS PRINT MUST BE CONSIDERED PROPRIETARY TO SNYDER INDUSTRIES, LLC, AND MAY NOT BE USED, COPIED, OR DISTRIBUTED WITHOUT WRITTEN PERMISSION OF AN OFFICER (OR HIS AGENT) OF THE FIRM.</small> |      | <small>TOLERANCES UNLESS OTHERWISE SPECIFIED:<br/>ANGULAR = ±1/2°<br/>FRACTIONAL = ±1/16"<br/>X = ±0.1", XX = ±.03", XXX = ±0.01"</small> | REVISION <b>A</b><br>SHEET 1 OF 1              |
|  |      | PART NO. <b>6820053B97203</b>   | ENG. ID. <b>D008319</b>                        |