

HEIGHT	PART NUMBER	DRAWING
X=33"	1947400M	<a href="#">D007096</a>
X=36"	1947500M	<a href="#">D007015</a>
X=39"	1947600M	<a href="#">D007097</a>
X=42"	1947700M	<a href="#">D007098</a>
X=45"	1947800M	<a href="#">D007102</a>
X=48"	1947900M	<a href="#">D007104</a>
X=51"	1948000M	<a href="#">D007105</a>
X=54"	1948100M	<a href="#">D007106</a>
X=56"	1948200M	<a href="#">D007107</a>
X=59"	1948300M	<a href="#">D007108</a>
X=62"	1948400M	<a href="#">D007017</a>

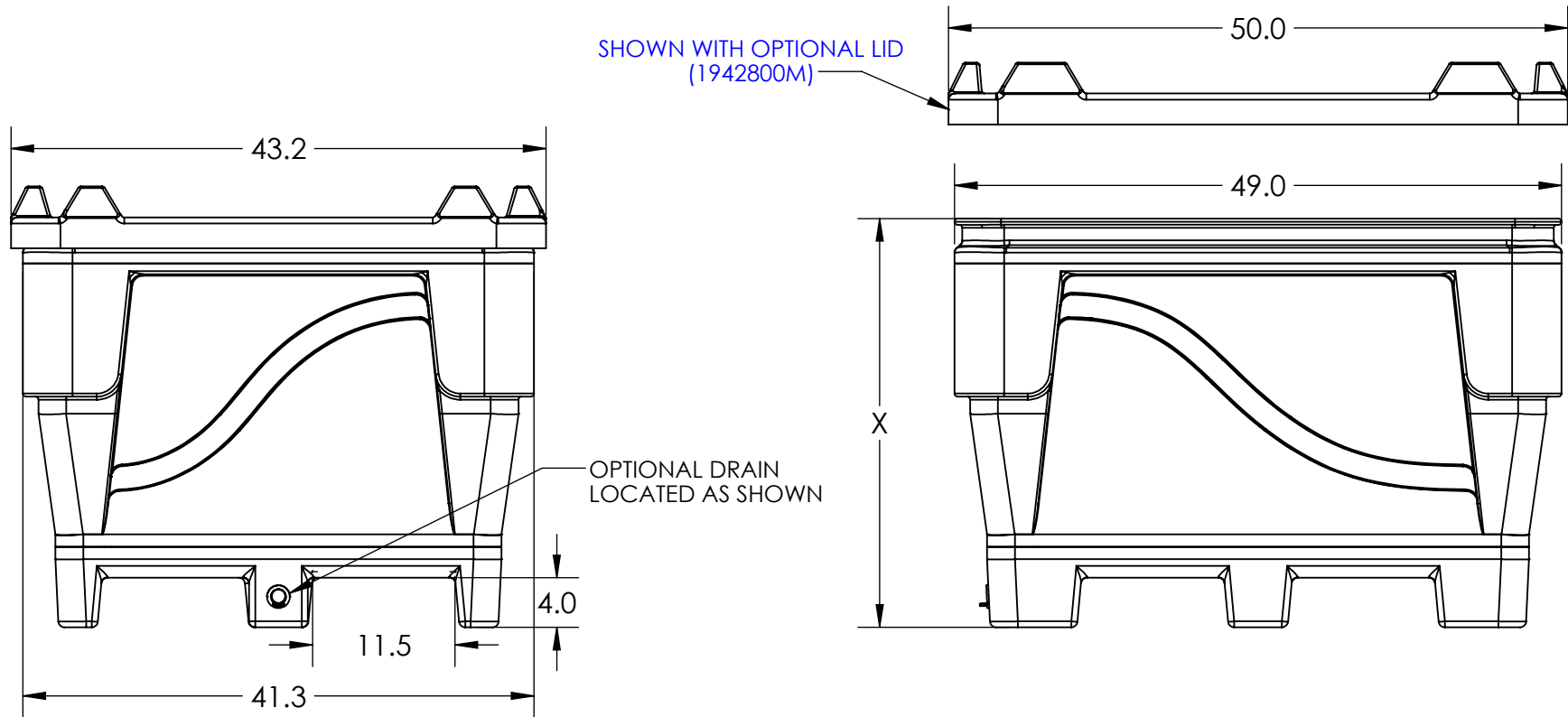

ALL DIMENSIONS ARE IN INCHES, NOMINAL, & SUBJECT TO CHANGE WITHOUT NOTICE.  
 ALL DIMENSIONS ON ROTATIONAL MOLDED PARTS ARE SUBJECT TO A ± 3% TOLERANCE.

DO NOT SCALE		DRAWN BY	BONAR PLASTICS WWW.BONARPLASTICS.COM		REVISION
STATUS:	Released	TJK	1005 Atlantic Drive West Chicago, IL 60185 (630)293-0303 www.bonarplastics.com		A
© SNYDER INDUSTRIES INC., 2017			TITLE: 6000 SERIES ARMOR BINS		SHEET 1 OF 1
ALL DIMENSIONS, DESIGNS, AND INFORMATION ON THIS PRINT MUST BE CONSIDERED PROPRIETARY TO SNYDER INDUSTRIES, INC. AND MAY NOT BE USED, COPIED, OR DISTRIBUTED WITHOUT WRITTEN PERMISSION OF AN OFFICER (OR HIS AGENT) OF THE FIRM.			PART NO.	ENG. ID.	D007288