

BLACK OR DARK OLIVE GREEN

PART NUMBER

1008600W94203	ASM TK 1000 VDT X 72 HD/BLK WATER
1008600W99803	ASM TK 1000 VDT X 72 HD/GDO WATER

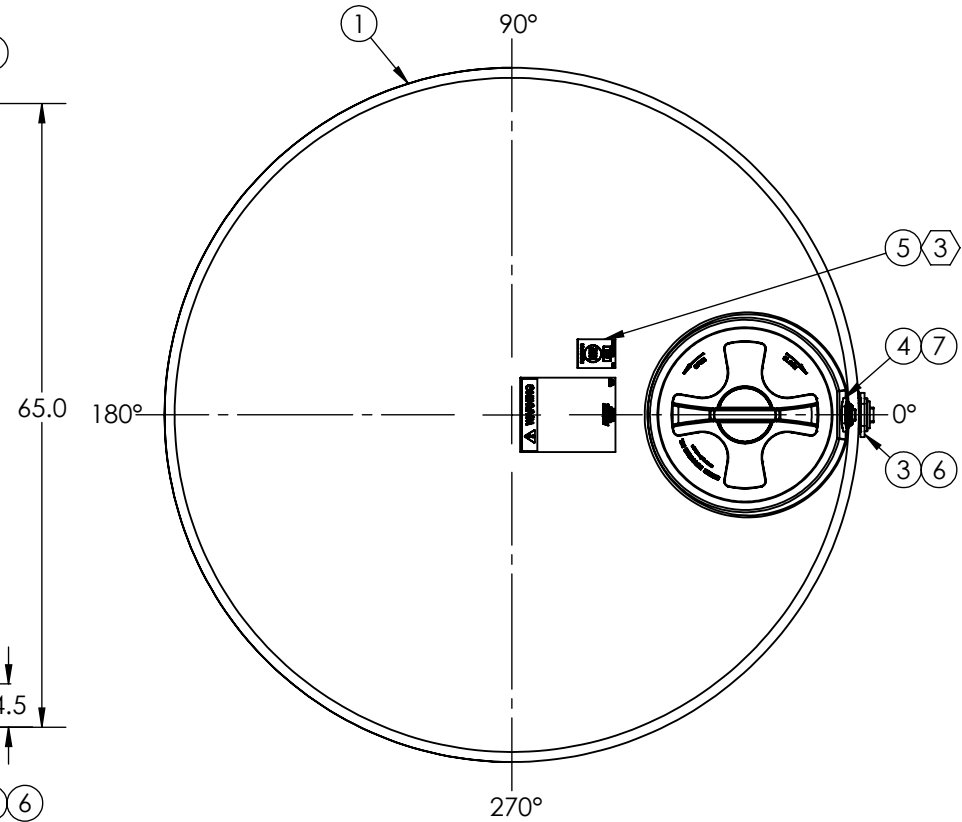
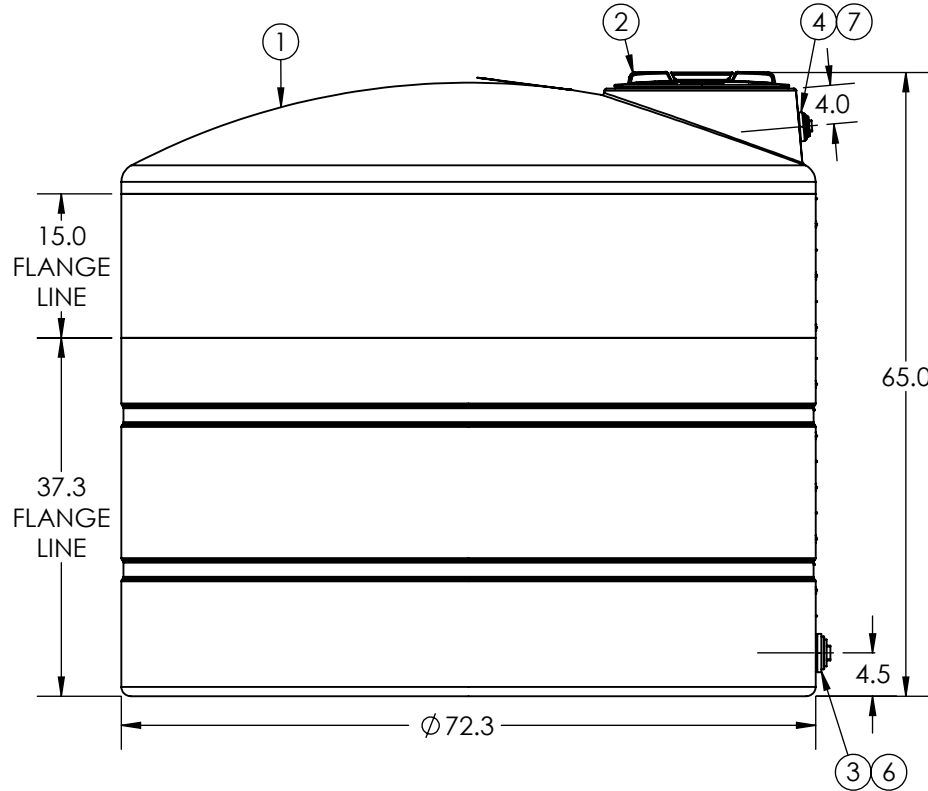

7	1	64149	1-1/2" NPT PLUG
6	1	60021	2" NPT PLUG
5	1	99700231	DECAL NSF MARK - WATER TKS
4	1	63931	FTG PP 1-1/2IN ECO-BH EPDM TXT
3	1	60405	FTG PP 2IN BH EPDM TXT
2	1	34700087	ASM MANWAY 18IN PE W/4IN VENT W/TIE SII
1	1	1008600W__02	ASM TK 1000 X 72 WATER NH NOMW

ITEM NO.	QTY.	PART NUMBER	DESCRIPTION
DO NOT SCALE		DRAWN BY	REVISION
STATUS: Released		SB	A
© SNYDER INDUSTRIES INC., 2017		TITLE: ASM TK 1000VDT X 72 WATER	
ALL DIMENSIONS, DESIGNS, AND INFORMATION ON THIS PRINT MUST BE CONSIDERED PROPRIETARY TO SNYDER INDUSTRIES, INC. AND MAY NOT BE USED, COPIED, OR DISTRIBUTED WITHOUT WRITTEN PERMISSION OF AN OFFICER (OR HIS AGENT) OF THE FIRM.		(402) 467-5221 www.snydernet.com	PART NO. 1008600W__03 ENG. ID. D006385

*ALL EXTERNAL PIPING MUST BE INDEPENDENTLY SUPPORTED.
 *ONLY BASE FITTINGS TO BE LEFT INSTALLED AT TIME OF SHIPMENT PER SII PROCEDURE.
 ALL DIMENSIONS ARE IN INCHES, NOMINAL, & SUBJECT TO CHANGE WITHOUT NOTICE.
 ALL DIMENSIONS ON ROTATIONAL MOLDED PARTS ARE SUBJECT TO A ± 3% TOLERANCE.