

BLACK OR DARK OLIVE GREEN

PART NUMBER	DESCRIPTION
5330200W94203	ASM TK 10000 VDT X 142 HD/BLK WATER
5330200W99803	ASM TK 10000 VDT X 142 HD/GDO WATER

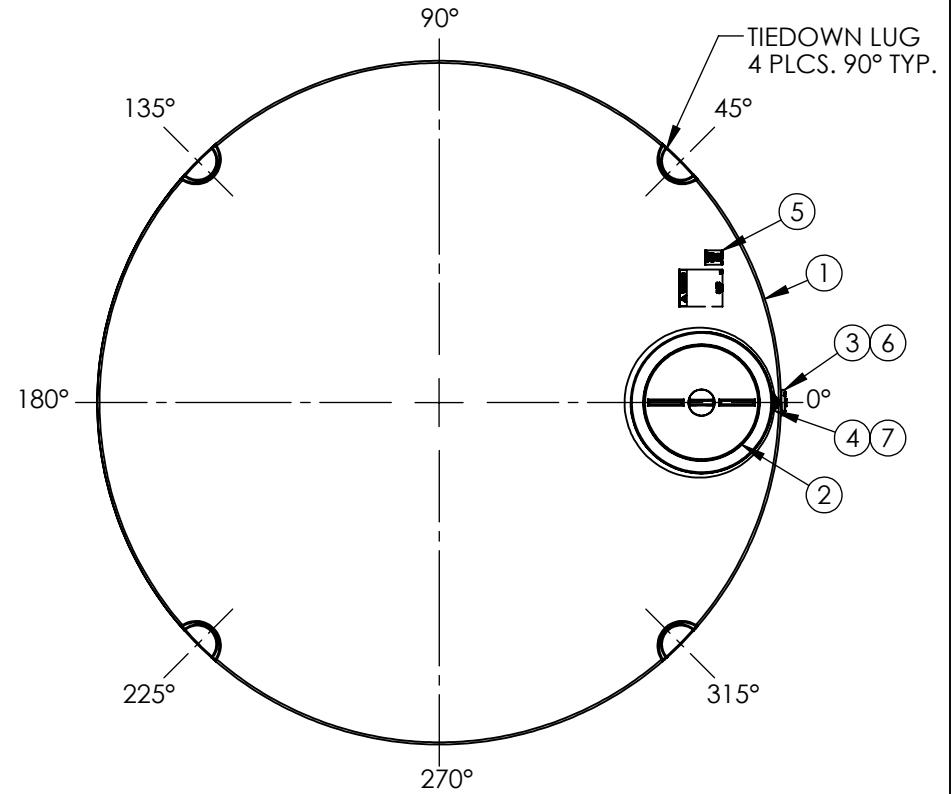
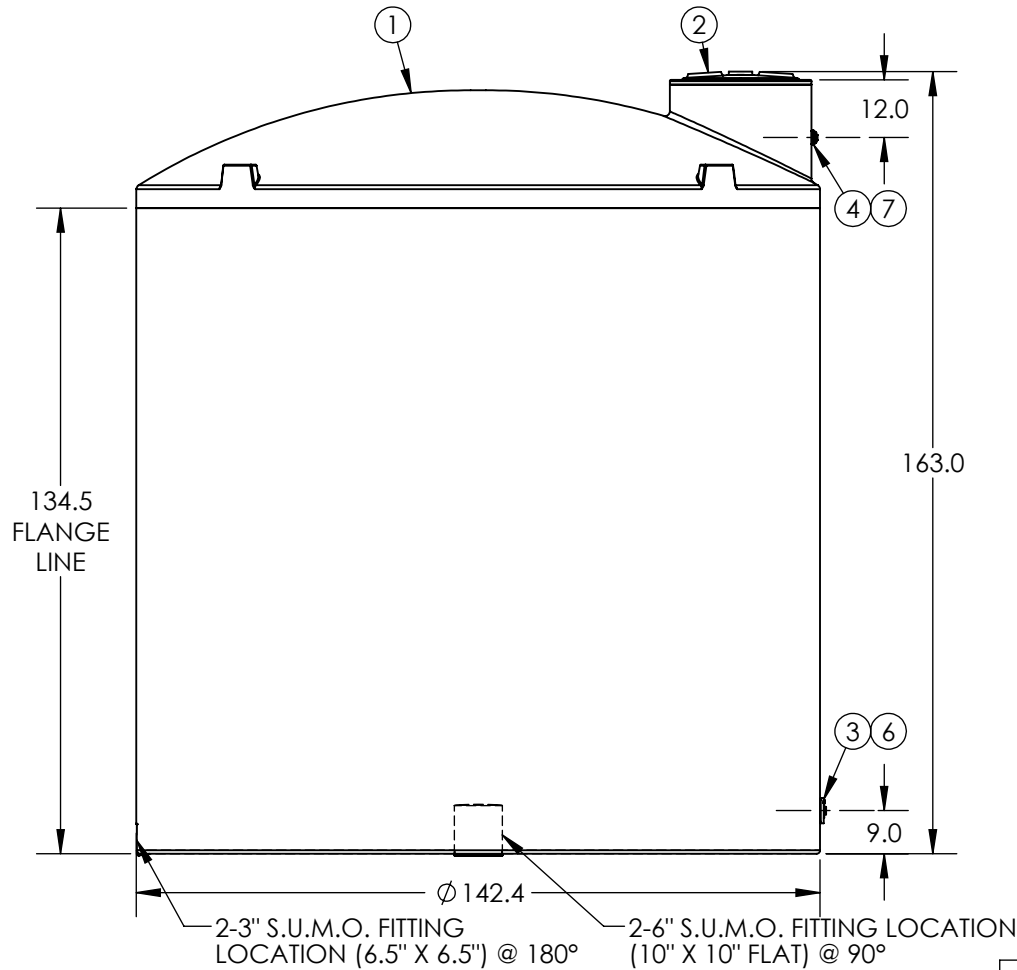

7	1	64149	1-1/2" NPT PLUG
6	1	60021	2" NPT PLUG
5	1	99700231	DECAL NSF MARK - WATER TKS
4	1	63931	FTG PP 1-1/2IN ECO-BH EPDM TXT
3	1	63683	FTG 2IN HD BH PP/EPDM
2	1	34700352	ASM MANWAY PE 24IN VENTED
1	1	5330200W__02	ASM TK 10000VDT X 142 NH NOMW

***ALL EXTERNAL PIPING MUST BE INDEPENDENTLY SUPPORTED.**
***ONLY BASE FITTINGS TO BE LEFT INSTALLED AT TIME OF SHIPMENT PER SII PROCEDURE.**
***Consult Snyder's Guidelines for Use and Installation prior to delivery.**
 Available on-line at <http://www.snyderindustriestanks.com/Technical>
ALL DIMENSIONS ARE IN INCHES, NOMINAL, & SUBJECT TO CHANGE WITHOUT NOTICE.
ALL DIMENSIONS ON ROTATIONAL MOLDED PARTS ARE SUBJECT TO A ± 3% TOLERANCE.

ITEM NO.	QTY.	PART NUMBER	DESCRIPTION
DO NOT SCALE		DRAWN BY	REVISION
STATUS: Released		IGG	B
© SNYDER INDUSTRIES INC., 2017		SII SNYDER INDUSTRIES, INC.	TITLE: ASM TK 10000VDT X 144
ALL DIMENSIONS, DESIGNS, AND INFORMATION ON THIS PRINT MUST BE CONSIDERED PROPRIETARY TO SNYDER INDUSTRIES, INC. AND MAY NOT BE USED, COPIED, OR DISTRIBUTED WITHOUT WRITTEN PERMISSION OF AN OFFICER (OR HIS AGENT) OF THE FIRM.		(402) 467-5221 www.snyderinet.com	SHEET 1 OF 1
PART NO. 5330200W__03		ENG. ID. D006361	