

PART NUMBER	GASKET MATERIAL
34100104	EPDM
34701142	VITON

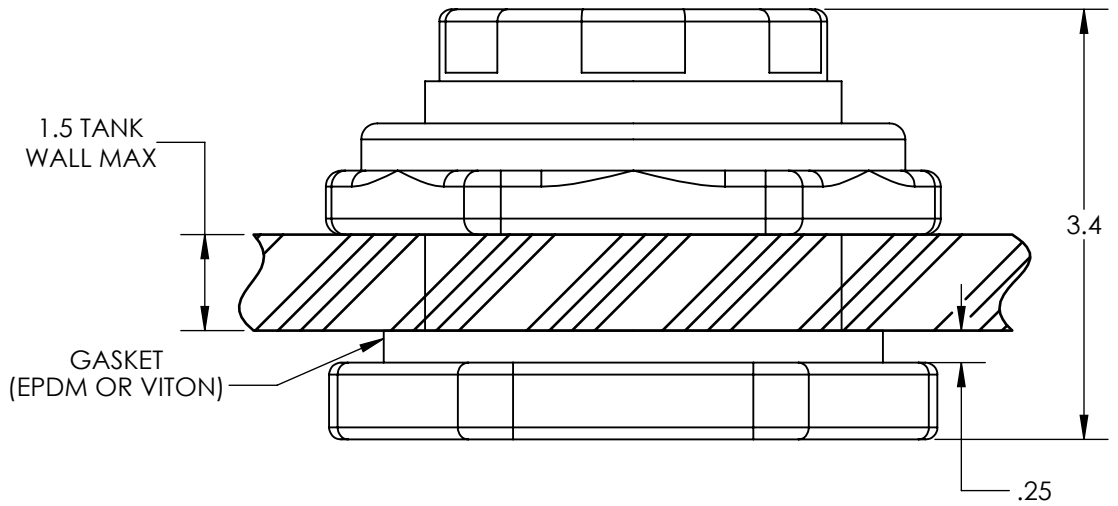
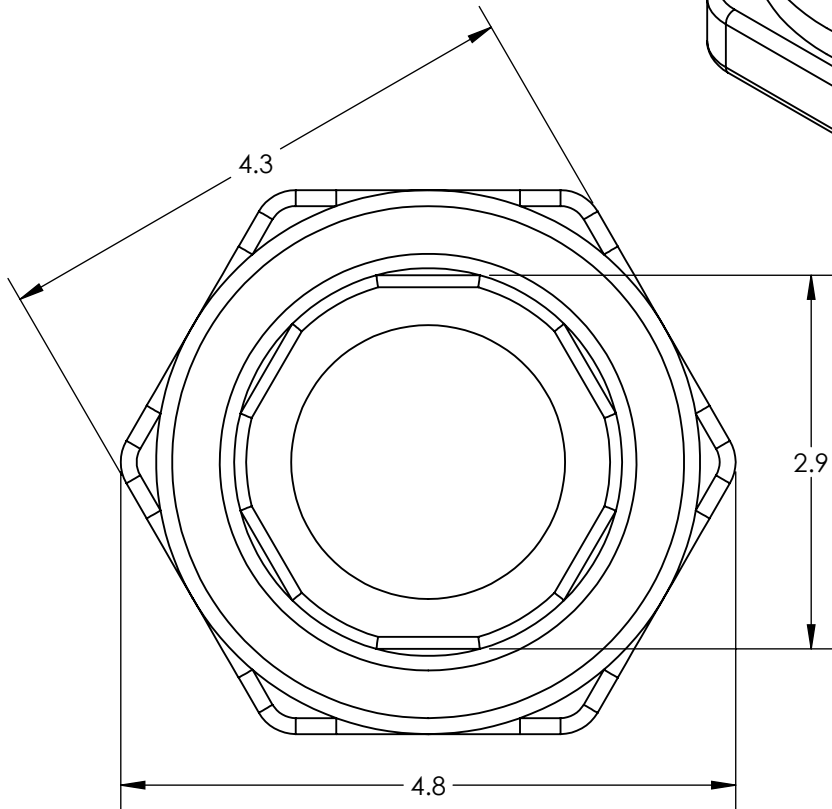
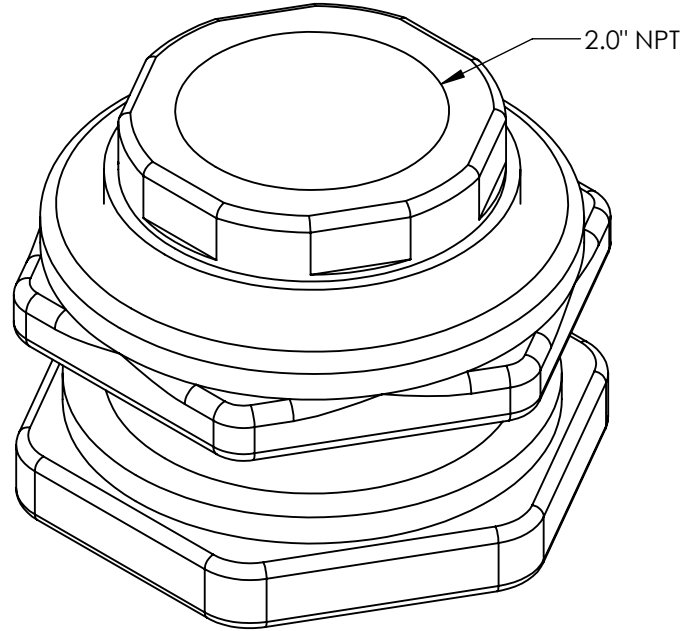

**\*ALL EXTERNAL PIPING MUST BE INDEPENDENTLY SUPPORTED.**  
**\*ONLY BASE FITTINGS TO BE LEFT INSTALLED AT TIME OF SHIPMENT PER SII PROCEDURE.**  
**\*TANKS ORDERED WITH FOAM INSULATION WILL HAVE AN INCREASED DIAMETER OF 4-6 INCHES.**  
**\*Consult Snyder's Guidelines for Use and Installation prior to delivery.**  
 Available on-line at <http://www.snyderindustriestanks.com/Technical>

**ALL DIMENSIONS ARE IN INCHES, NOMINAL, & SUBJECT TO CHANGE WITHOUT NOTICE.**  
**ALL DIMENSIONS ON ROTATIONAL MOLDED PARTS ARE SUBJECT TO A ± 3% TOLERANCE.**

DO NOT SCALE		DRAWN BY		TITLE:	<b>FTG PP 2IN BH</b>	REVISION
STATUS:	<b>Released</b>	IGG		ENG. ID.		<b>C</b>
© SNYDER INDUSTRIES, LLC, 2019			(402) 467-5221 <a href="http://www.snyderinet.com">www.snyderinet.com</a>	PART NO.	<b>SEE CHART</b>	SHEET
<small>ALL DIMENSIONS, DESIGNS, AND INFORMATION ON THIS PRINT MUST BE CONSIDERED PROPRIETARY TO SNYDER INDUSTRIES, LLC, AND MAY NOT BE USED, COPIED, OR DISTRIBUTED WITHOUT WRITTEN PERMISSION OF AN OFFICER (OR HIS AGENT) OF THE FIRM.</small>		<b>D003208</b>		1 OF 1		