

1/4"-20 SS INSERT LOCATIONS

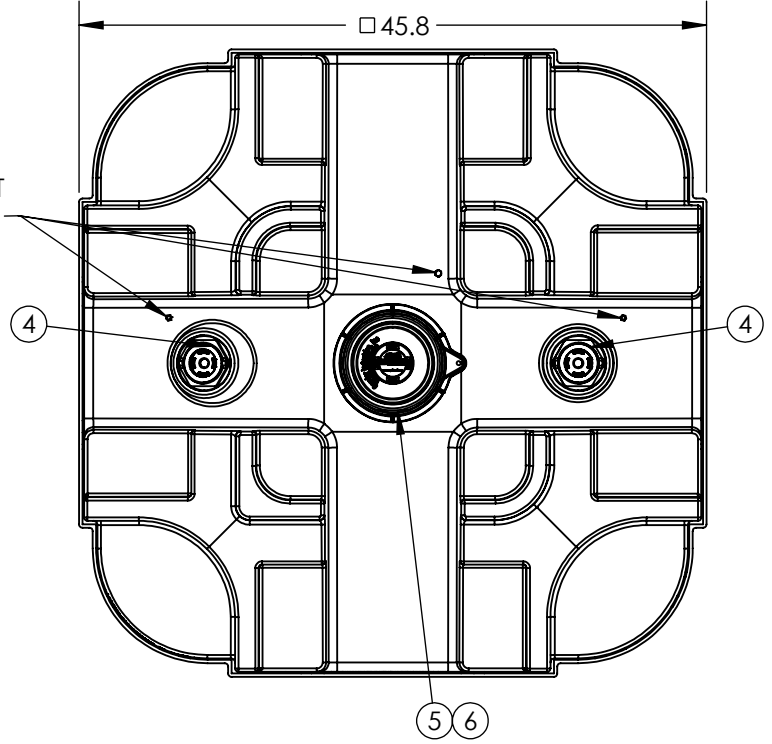

STANDARD 275 SQUARE STACKABLE "STANDARD PACKAGE OF EQUIPMENT"

7	1	34701262	STD IBC ASSEMBLY KIT W/BAG
6	1	34700822	ASM VENT PE 2IN VACUUM SII W/EPDM
5	1	34700391	ASM CAP PE 6IN H.DUTY 2IN NPS-EPDM W/TIE
4	2	34700340	ASM PLUG 2IN NPS BUNG W/EPDM-WHITE
3	1	34702616	ASM VALVE 2IN 4-BOLT STUBBY 100KPA
2	1	6550000B96701	ASM BASE SQ STK H.DUTY HD/BLK
1	1	6620030B97201	ASM TK 275 SQ HD/NAT BDR 2RB/3INS 6CAP

UN MARKING READS:

31H2/Y/ / /USA
SNYDER IND. INC.
LINCOLN, NE 3730 / 2072
CAPACITY - 1041 LITERS
TARE MASS - KG
GAUGE TEST PRESSURE - 100 KPA
LAST LEAKPROOFNESS TEST - /
LAST INSPECTION - /

SNYDER INDUSTRIES, INC U.N. MARKED CONTAINER CLOSURE NOTIFICATION.
 ALL DIMENSIONS ARE IN INCHES, NOMINAL, & SUBJECT TO CHANGE WITHOUT NOTICE.
 ALL DIMENSIONS ON ROTATIONAL MOLDED PARTS ARE SUBJECT TO A ± 3% TOLERANCE.

DO NOT SCALE		DRAWN BY		TITLE:	ASM TK 275 SQ NAT 2RB/3INS 6C HDBLK EPDM	REVISION
Released		ET3		6620030B97204		D002991
© SNYDER INDUSTRIES INC., 2017		ALL DIMENSIONS, DESIGNS, AND INFORMATION ON THIS PRINT MUST BE CONSIDERED PROPRIETARY TO SNYDER INDUSTRIES, INC. AND MAY NOT BE USED, COPIED, OR DISTRIBUTED WITHOUT WRITTEN PERMISSION OF AN OFFICER (OR HIS AGENT) OF THE FIRM.		(402) 467-5221 www.snyderinet.com	PART NO. 6620030B97204	ENG. ID. D002991