

HEIGHT	PART NUMBER	DRAWING
X=33"	1015200M	D002849
X=36"	1015300M	D002850
X=39"	1015400M	D002851
X=42"	1015500M	D002852
X=45"	1015600M	D002853
X=48"	1015700M	D002855
X=51"	1015800M	D002856
X=56"	1015900M	D002857
X=62"	1031000M	D002858

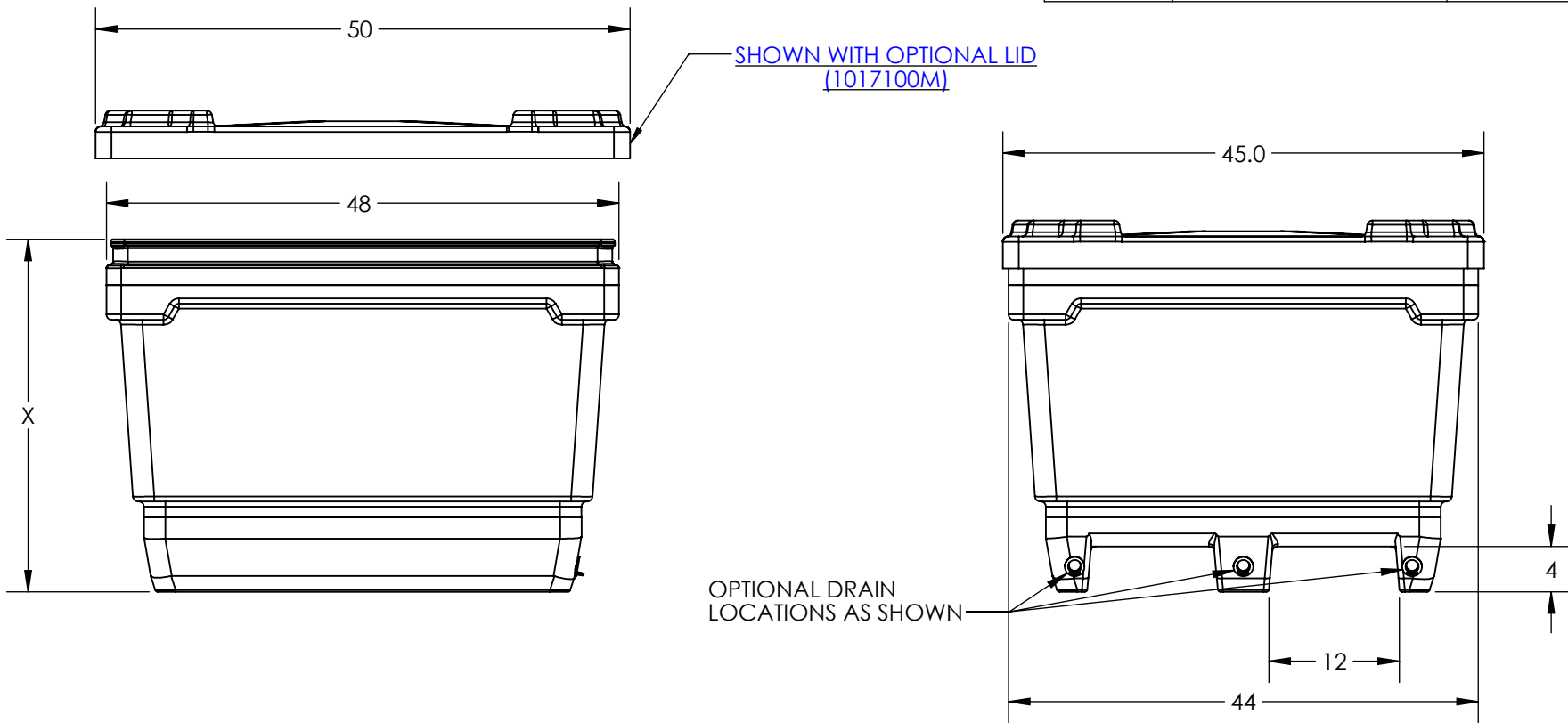

ALL DIMENSIONS ARE IN INCHES, NOMINAL, & SUBJECT TO CHANGE WITHOUT NOTICE.
ALL DIMENSIONS ON ROTATIONAL MOLDED PARTS ARE SUBJECT TO A \pm 3% TOLERANCE.

DO NOT SCALE	DRAWN BY	DATE	 www.bonarpastics.com 1005 Atlantic Drive West Chicago, IL 60185 (630)293-0303 www.bonarpastics.com	TITLE:	ASM 2800 MONSTER COMBO	REVISION
STATUS:	ET3	12/31/2013		PART NO.		ENG. ID.
© SNYDER INDUSTRIES INC., 2013						SHEET 1 OF 1
<small>ALL DIMENSIONS, DESIGNS, AND INFORMATION ON THIS PRINT MUST BE CONSIDERED PROPRIETARY TO SNYDER INDUSTRIES, INC. AND MAY NOT BE USED, COPIED, OR DISTRIBUTED WITHOUT WRITTEN PERMISSION OF AN OFFICER (OR HIS AGENT) OF THE FIRM.</small>						D001418