

APPROX. BRIMFUL CAPACITY:
TANK: 72 GAL.

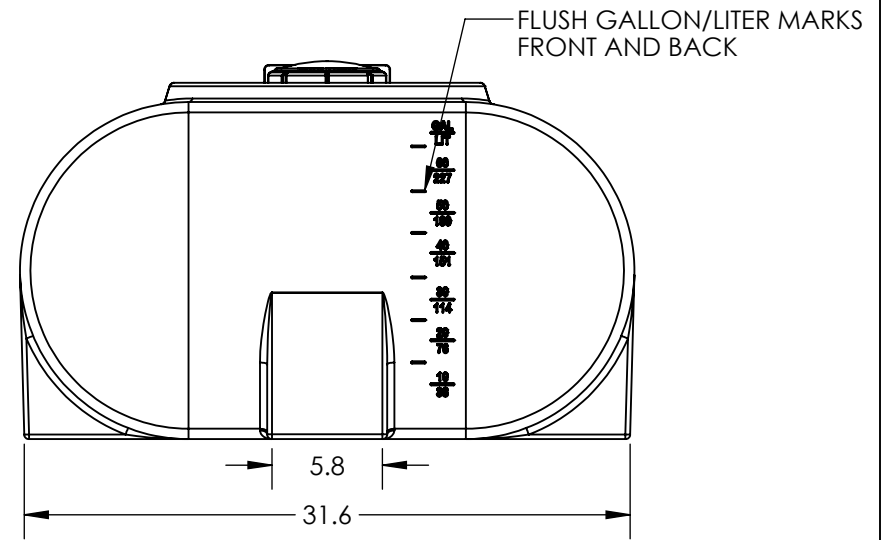
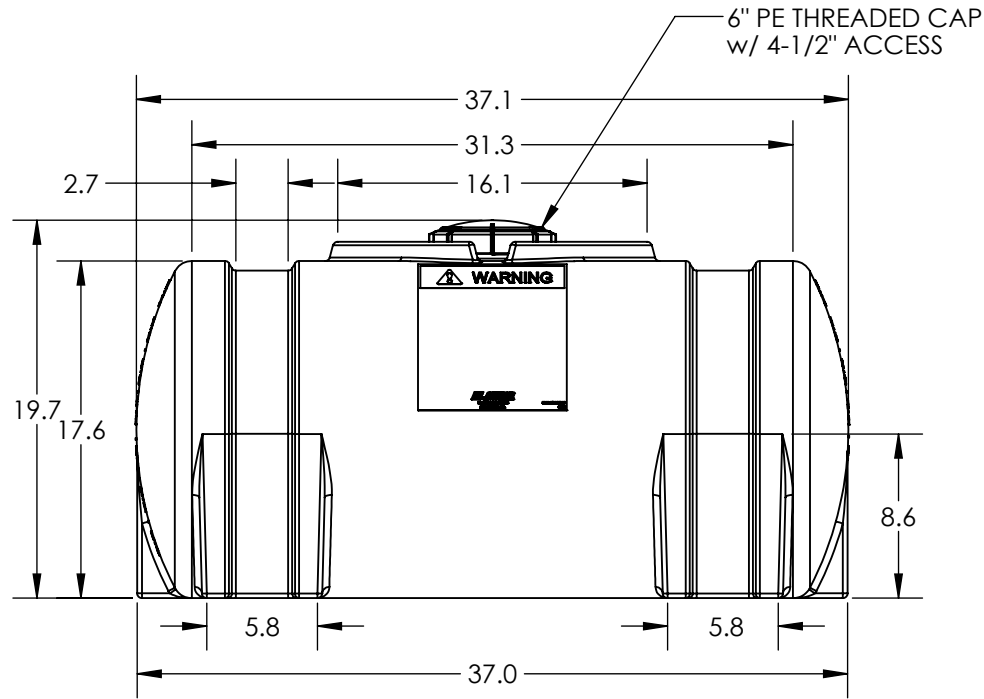

*ALL EXTERNAL PIPING MUST BE INDEPENDENTLY SUPPORTED.
 *ONLY BASE FITTINGS TO BE LEFT INSTALLED AT TIME OF SHIPMENT PER SII PROCEDURE.
 *TANKS ORDERED WITH FOAM INSULATION WILL HAVE AN INCREASED DIAMETER OF 4-6 INCHES.
 *Consult Snyder's Guidelines for Use and Installation prior to delivery.
 Available on-line at <http://www.snyderindustriestanks.com/Technical>

ALL DIMENSIONS ARE IN INCHES, NOMINAL, & SUBJECT TO CHANGE WITHOUT NOTICE.
 ALL DIMENSIONS ON ROTATIONAL MOLDED PARTS ARE SUBJECT TO A ± 3% TOLERANCE.

DO NOT SCALE		DRAWN BY		TITLE:	REVISION
STATUS:	Released	SB		ASM TK 65HL X 32 SII NH	A
© SNYDER INDUSTRIES, LLC, 2019			(402) 467-5221 www.snyder.net	PART NO.	ENG. ID.
<small>ALL DIMENSIONS, DESIGNS, AND INFORMATION ON THIS PRINT MUST BE CONSIDERED PROPRIETARY TO SNYDER INDUSTRIES, LLC, AND MAY NOT BE USED, COPIED, OR DISTRIBUTED WITHOUT WRITTEN PERMISSION OF AN OFFICER (OR HIS AGENT) OF THE FIRM.</small>				1031500N__01	D000582
				SHEET	1 OF 1