

ITEM NO.	QTY.	PART NUMBER	DESCRIPTION
1	1	1003600N__01	ASM TK 125HL X 32
2	1	1003700N	ASM 125HL X 32 STAND
3	1	1003800N	ASM 125HL/STAND CONTAINMENT

APPROX. BRIMFUL CAPACITY:
 TANK: 135.6 GAL.
 CONTAINMENT: 167.1 GAL.

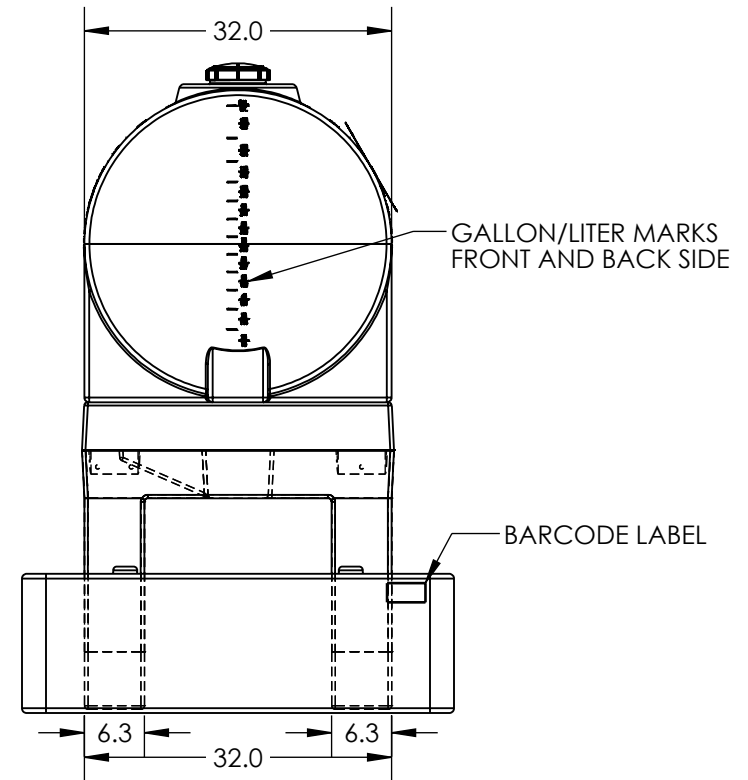
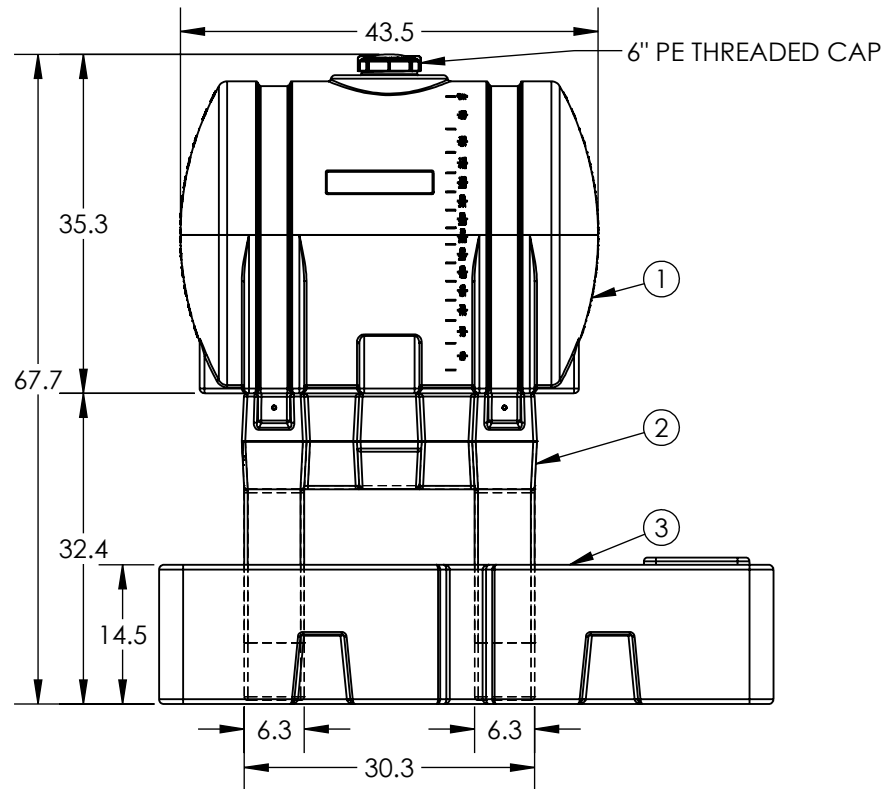

***ALL EXTERNAL PIPING MUST BE INDEPENDENTLY SUPPORTED.**
***ONLY BASE FITTINGS TO BE LEFT INSTALLED AT TIME OF SHIPMENT PER SII PROCEDURE.**
***TANKS ORDERED WITH FOAM INSULATION WILL HAVE AN INCREASED DIAMETER OF 4-6 INCHES.**
***Consult Snyder's Guidelines for Use and Installation prior to delivery.**
 Available on-line at <http://www.snyderindustriestanks.com/Technical>

ALL DIMENSIONS ARE IN INCHES, NOMINAL, & SUBJECT TO CHANGE WITHOUT NOTICE.
ALL DIMENSIONS ON ROTATIONAL MOLDED PARTS ARE SUBJECT TO A ± 3% TOLERANCE.

DO NOT SCALE		DRAWN BY	TITLE:		REVISION
STATUS: Released		IGG	ASM 125HL/STAND/CONTAINMENT		A
© TANK HOLDING, CORP, 2023			A BRAND OF TANK HOLDING CORP.		SHEET 1 OF 1
ALL DIMENSIONS, DESIGNS, AND INFORMATION ON THIS PRINT MUST BE CONSIDERED PROPRIETARY TO TANK HOLDING, CORP. AND MAY NOT BE USED, COPIED, OR DISTRIBUTED WITHOUT WRITTEN PERMISSION OF AN OFFICER (OR HIS AGENT) OF THE FIRM.			(402) 467-5221 www.snydermet.com		
PART NO. 1003600N		ENG. ID. A015470			