

CUSTOMIZABLE LOGO 13" X 5.5"

#	TOP OPTIONS
<input type="checkbox"/> 1	SLOPE TOP 12" FILLNECK NO TOP LIFT INSERTS
<input type="checkbox"/> 2	SLOPE TOP 12" FILLNECK NO TOP LIFT
<input type="checkbox"/> 3	SLOPE TOP 22" SANITARY NO TOP LIFT INSERTS
<input type="checkbox"/> 4	SLOPE TOP 22" SANITARY NO TOP LIFT
<input type="checkbox"/> 5	12" FILLNECK WITH HEAVY LIFT

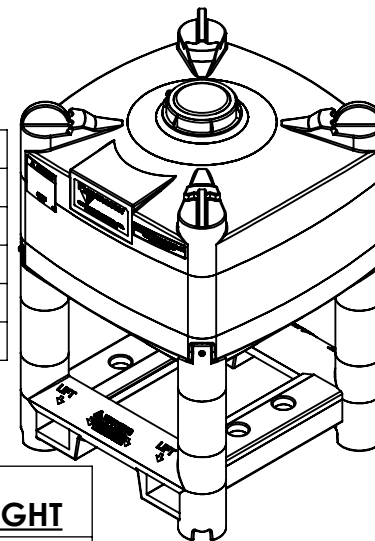

SIZE	(A) OVERALL HEIGHT	(B) NESTING HEIGHT
<input type="checkbox"/> 190G	56.9"	51.6"
<input type="checkbox"/> 299G	69.5"	64.2"
<input type="checkbox"/> 375G	76.5"	71.2"
<input type="checkbox"/> 449G	86.6"	81.3"
<input type="checkbox"/> 524G	93.5"	88.2"
<input type="checkbox"/> 598G	102.7"	97.4"
MAX HEIGHT FOR SHIPPING IS 106"		

OUTLET OPTIONS
<input type="checkbox"/> Ø2-3" VERTICAL
<input type="checkbox"/> Ø2-3" HORIZONTAL *
<input type="checkbox"/> Ø2" VERTICAL EXTERNAL THREAD
<input type="checkbox"/> 6.5" GEM

STAND OPTIONS
<input type="checkbox"/> SANITARY
<input type="checkbox"/> ORIGINAL

ADDITIONAL OPTIONS
<input type="checkbox"/> SANITARY FINISH PROCESS
<input type="checkbox"/> CUSTOM MARKINGS
<input type="checkbox"/> CUSTOM LOGO
<input type="checkbox"/> PROTECTIVE WRAP

ADDITIONAL COMPONENTS

QTY	P/N	DESCRIPTION

* HORIZONTAL OUTLET TANKS REQUIRE A 3" TALLER BASE. ADD 3" TO ALL HEIGHT DIMENSIONS SHOWN.

ALL DIMENSIONS ARE IN INCHES, NOMINAL, & SUBJECT TO CHANGE WITHOUT NOTICE. ALL DIMENSIONS ON ROTATIONAL MOLDED PARTS ARE SUBJECT TO A ± 3% TOLERANCE.

DO NOT SCALE	DRAWN BY	SNYDER INDUSTRIES, INC.	TITLE:	45° VISCOUS FLOWMASTER	REVISION
STATUS: Released	SB		ENG. ID.		A
© SNYDER INDUSTRIES INC., 2017		(402) 467-5221 www.snydernet.com	PART NO.	ENG. ID.	A007211
ALL DIMENSIONS, DESIGNS, AND INFORMATION ON THIS PRINT MUST BE CONSIDERED PROPRIETARY TO SNYDER INDUSTRIES, INC. AND MAY NOT BE USED, COPIED, OR DISTRIBUTED WITHOUT WRITTEN PERMISSION OF AN OFFICER (OR HIS AGENT) OF THE FIRM.			SHEET 1 OF 1		