

**50/50 LID  
7801400E/7801500E**

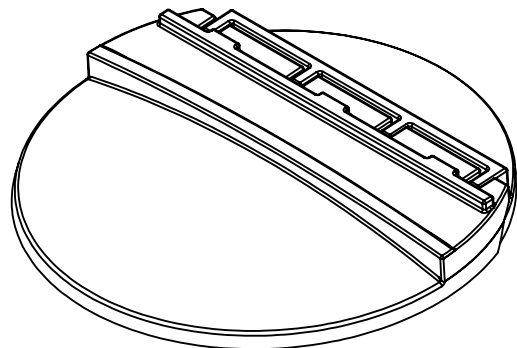

**70/30 LID  
7801300E**

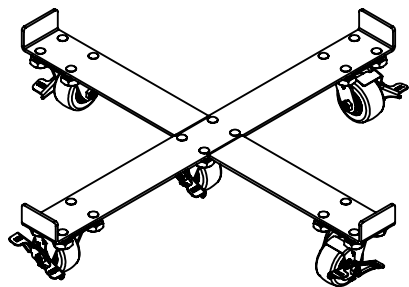

**CASTER BASE  
34702373**

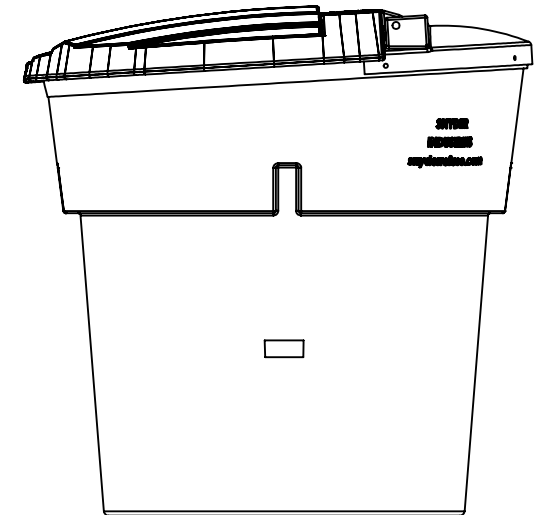
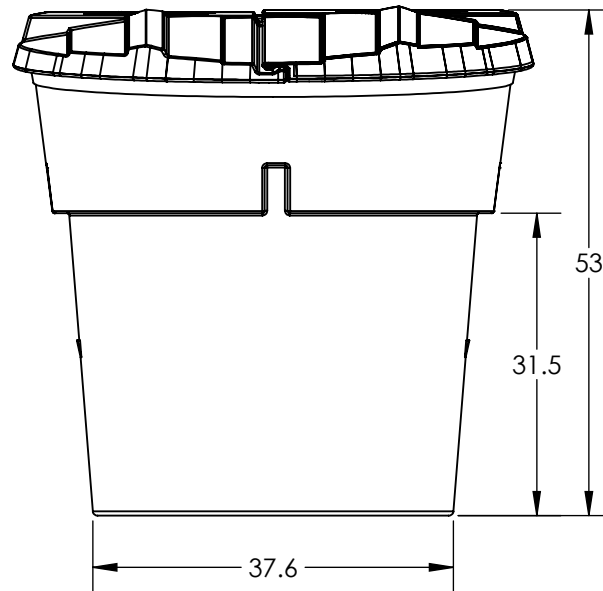

	HDPE
CAN WEIGHT (LBS.)	65
FULL ASSEMBLY WEIGHT (LBS.)	87
WEIGHT CAPACITY (LBS.)	500
VOLUME (GALLONS)	300
NOMINAL THICKNESS (IN)	0.200
MINIMUM COMPRESSION FORCE (LBS.)	200
PALLET SHIPPING QUANTITY	10
PREDRILLED LID HOLES	4

**\*ALL COMPONENTS ARE SHIPPED LOOSE AND TO BE INSTALLED BY THE END USER.  
ALL DIMENSIONS ARE IN INCHES, NOMINAL, & SUBJECT TO CHANGE WITHOUT NOTICE.  
ALL DIMENSIONS ON ROTATIONAL MOLDED PARTS ARE SUBJECT TO A ± 3% TOLERANCE.**

DO NOT SCALE		DRAWN BY	TITLE:		REVISION
STATUS: <b>Released</b>		TS	<b>CAN 300G CNTR</b>		<b>A</b>
© TANK HOLDING, CORP, 2025			 A BRAND OF TANK HOLDING CORP.		SHEET
<small>ALL DIMENSIONS, DESIGNS, AND INFORMATION ON THIS PRINT MUST BE CONSIDERED PROPRIETARY TO TANK HOLDING, CORP. AND MAY NOT BE USED, COPIED, OR DISTRIBUTED WITHOUT WRITTEN PERMISSION OF AN OFFICER (OR HIS AGENT) OF THE FIRM.</small>			<small>(402) 467-5221</small> <a href="http://www.snydernet.com">www.snydernet.com</a>		1 OF 1
PART NO.		ENG. ID.			
<b>7801000E</b>		<b>A002461</b>			